

# Tessera Roll+

## Basic Version + ⚡ E-KIT



## Installation Manual

PART NUMBER(S)	Model Year
TESS 1425 ROLL+ E-KIT	Chevrolet Silverado / GMC Sierra 2014 -> 2018 & 2019+
TESS 1428 ROLL+ E-KIT	Chevrolet Silverado / GMC Sierra 2019+
Cab(s)	Installation Time / Weight
Short Bed 5.8" & Standard Bed 6.6"	40-60 minutes / 53-57 kg



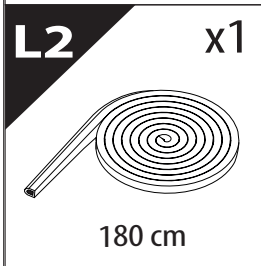
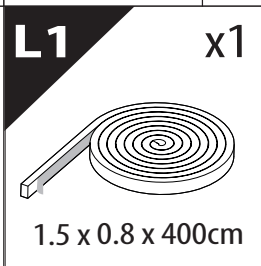
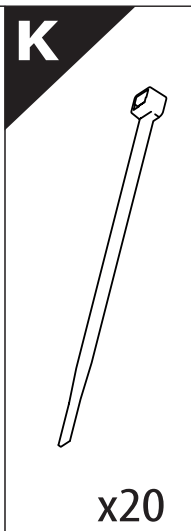
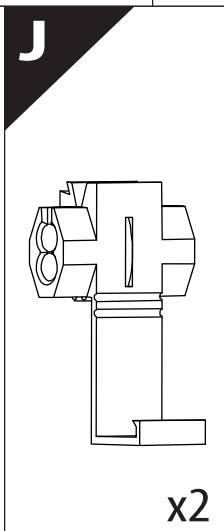
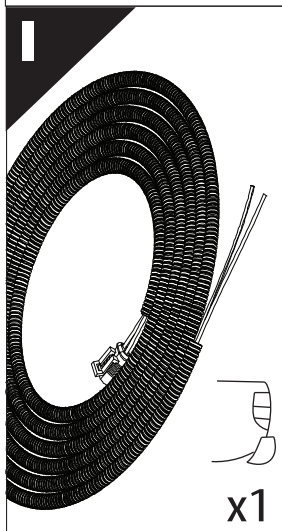
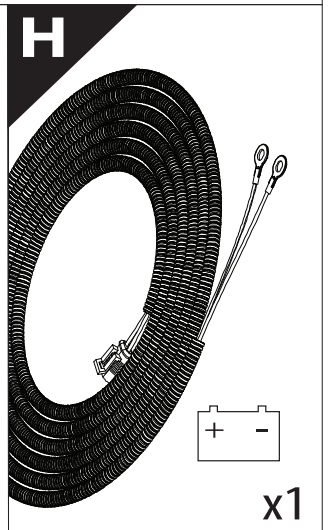
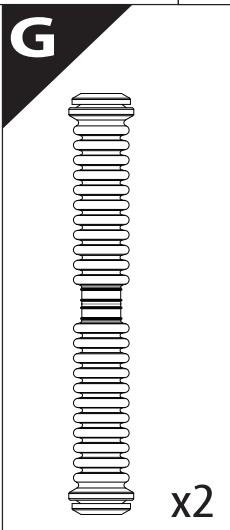
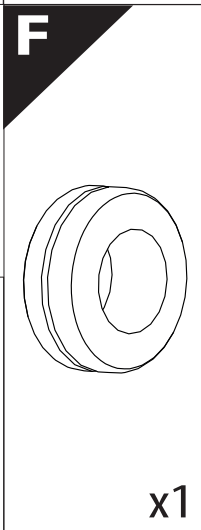
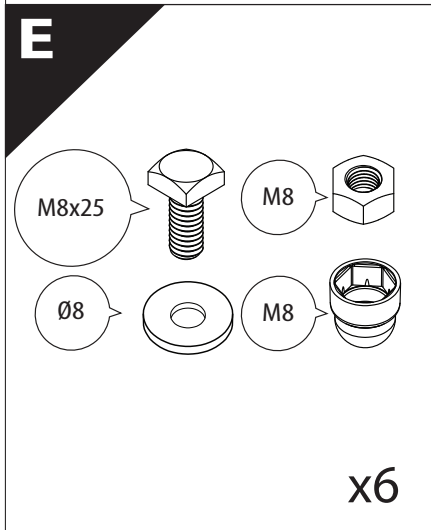
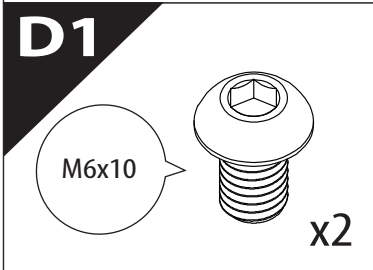
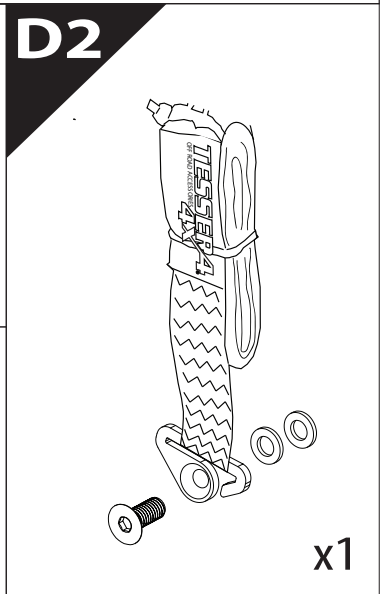
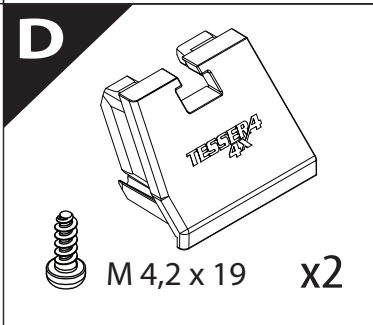
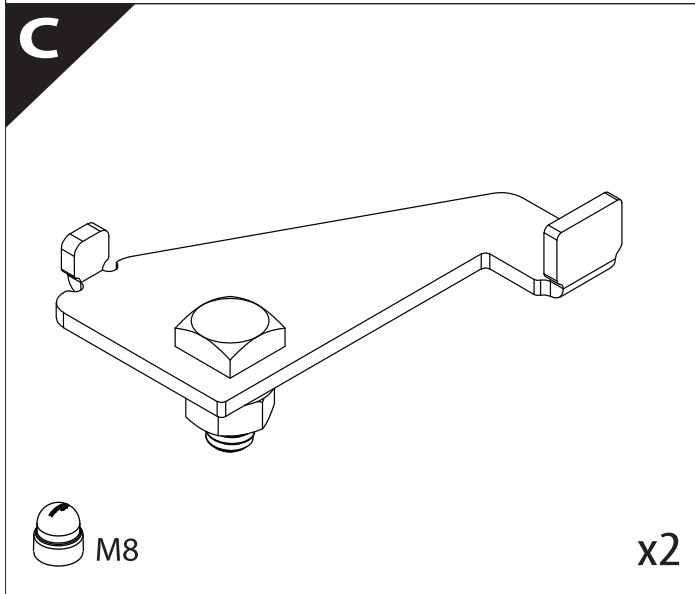
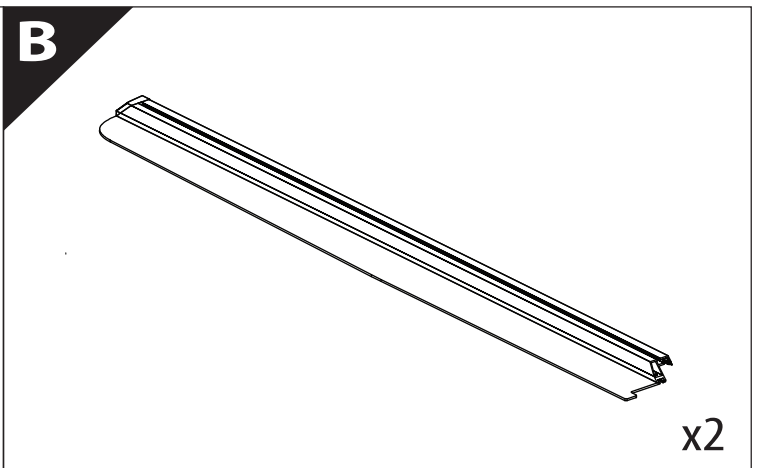
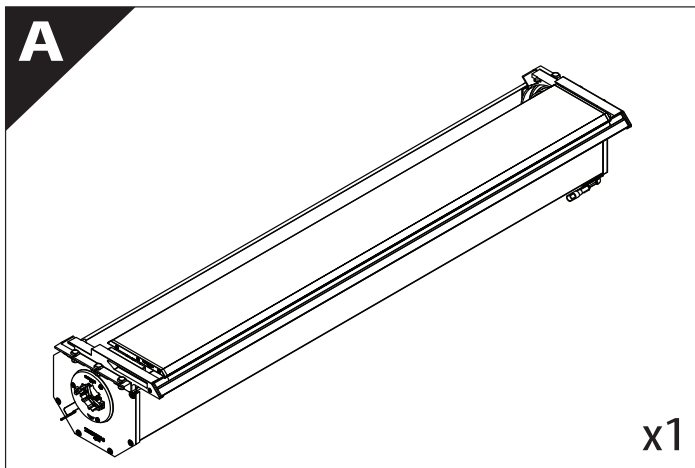

**M2**

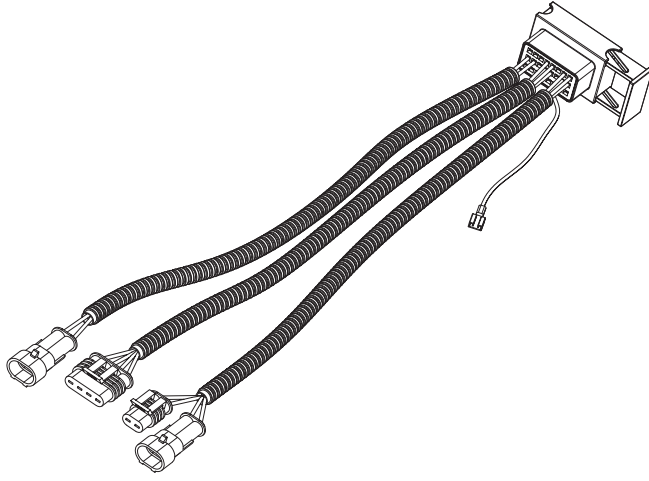

x1

**N**

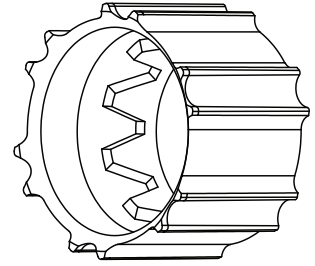

x1

**O**

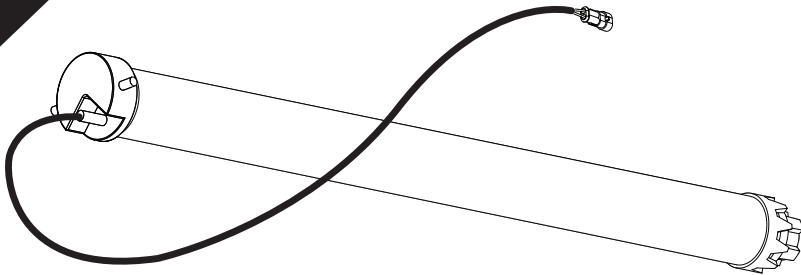

x1

**P**

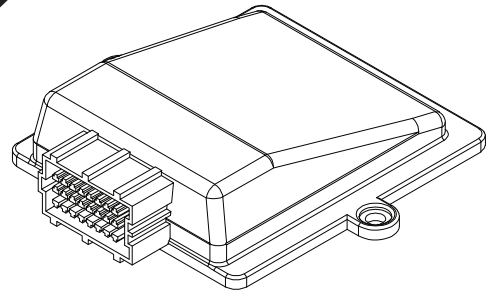

x1

**Q**

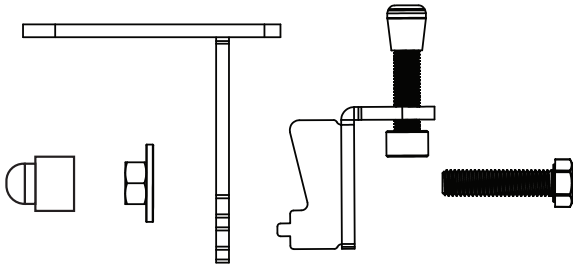

x6

**R**

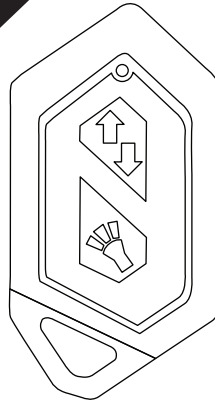

x2

**S**



x2

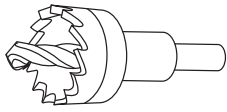

Ø 25 mm

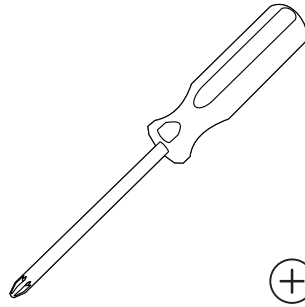
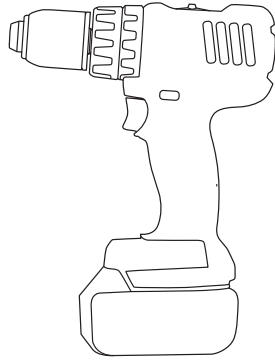

+

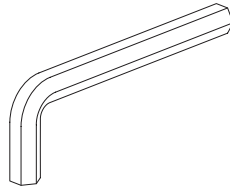
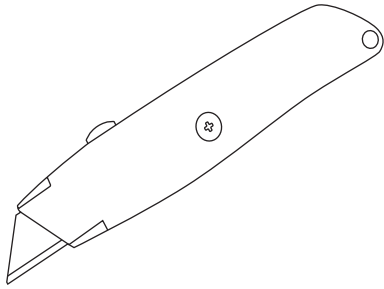
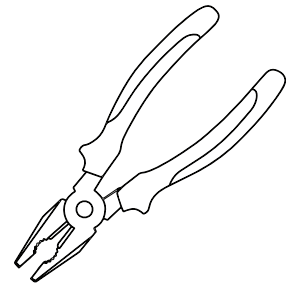

4 mm

1 - 25 Nm

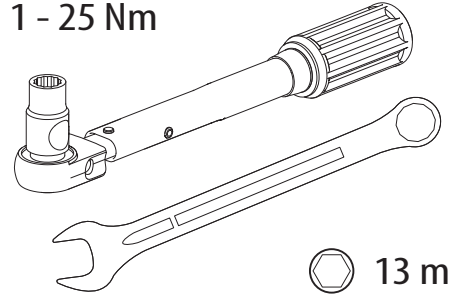

13 mm



ACETONE

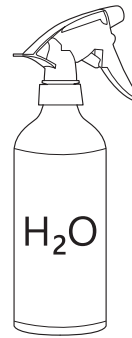
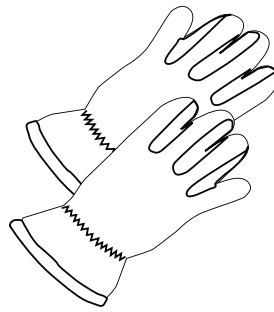
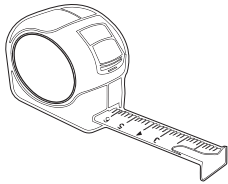

H<sub>2</sub>O

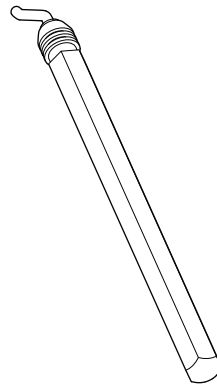
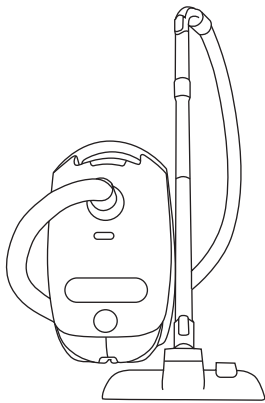
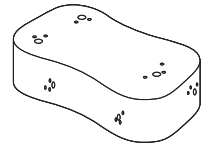

ANTI-RUST



INSTALLATION  
MANUAL  
+E-KIT

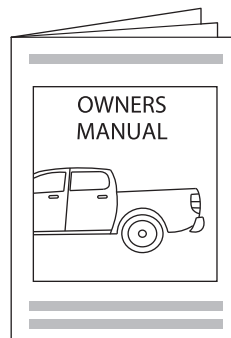

OWNERS  
MANUAL



x1

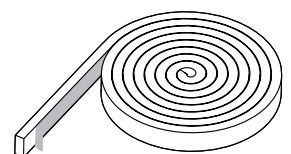
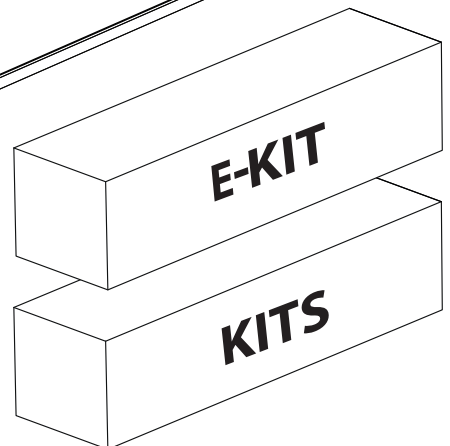
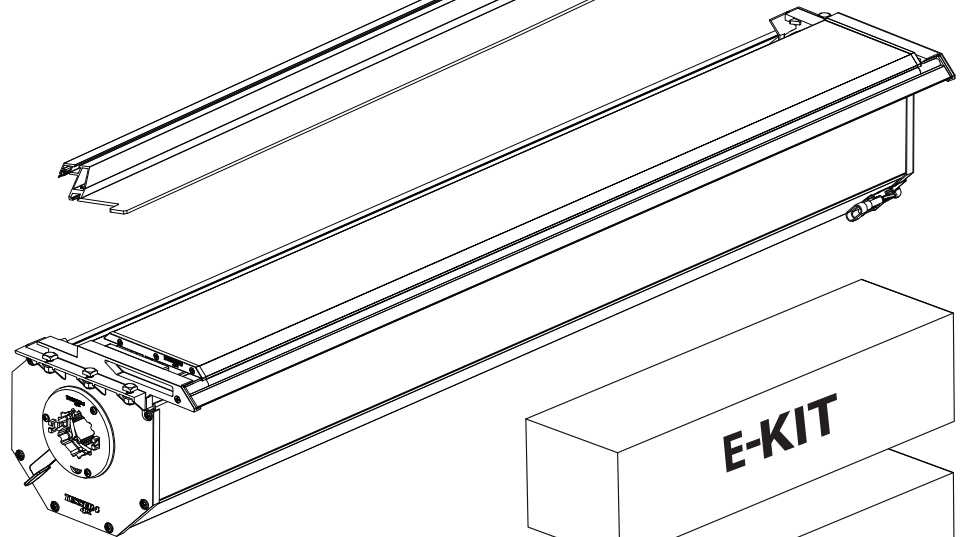
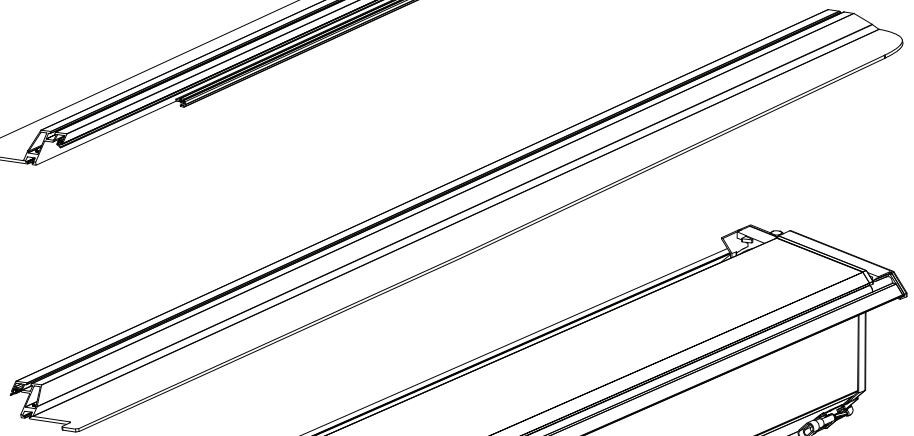
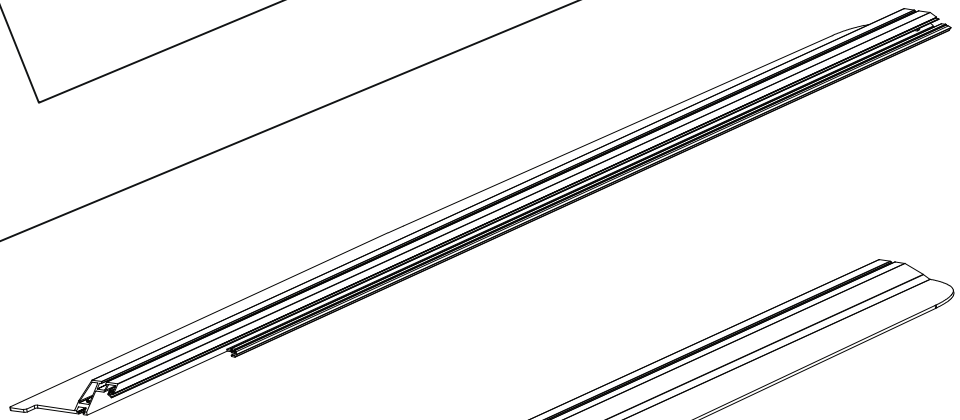
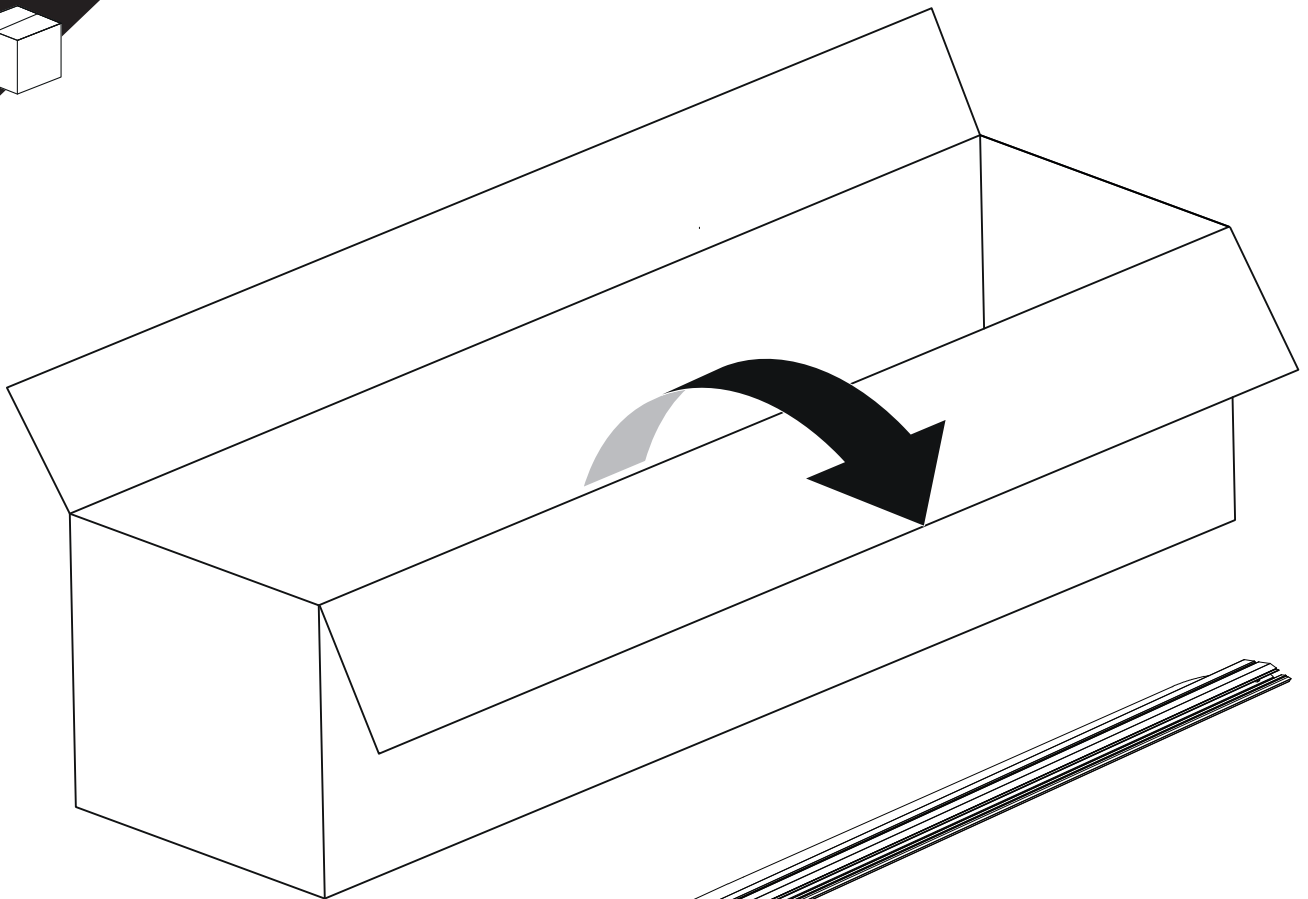

**B**

**A**

**KITS**

**L**

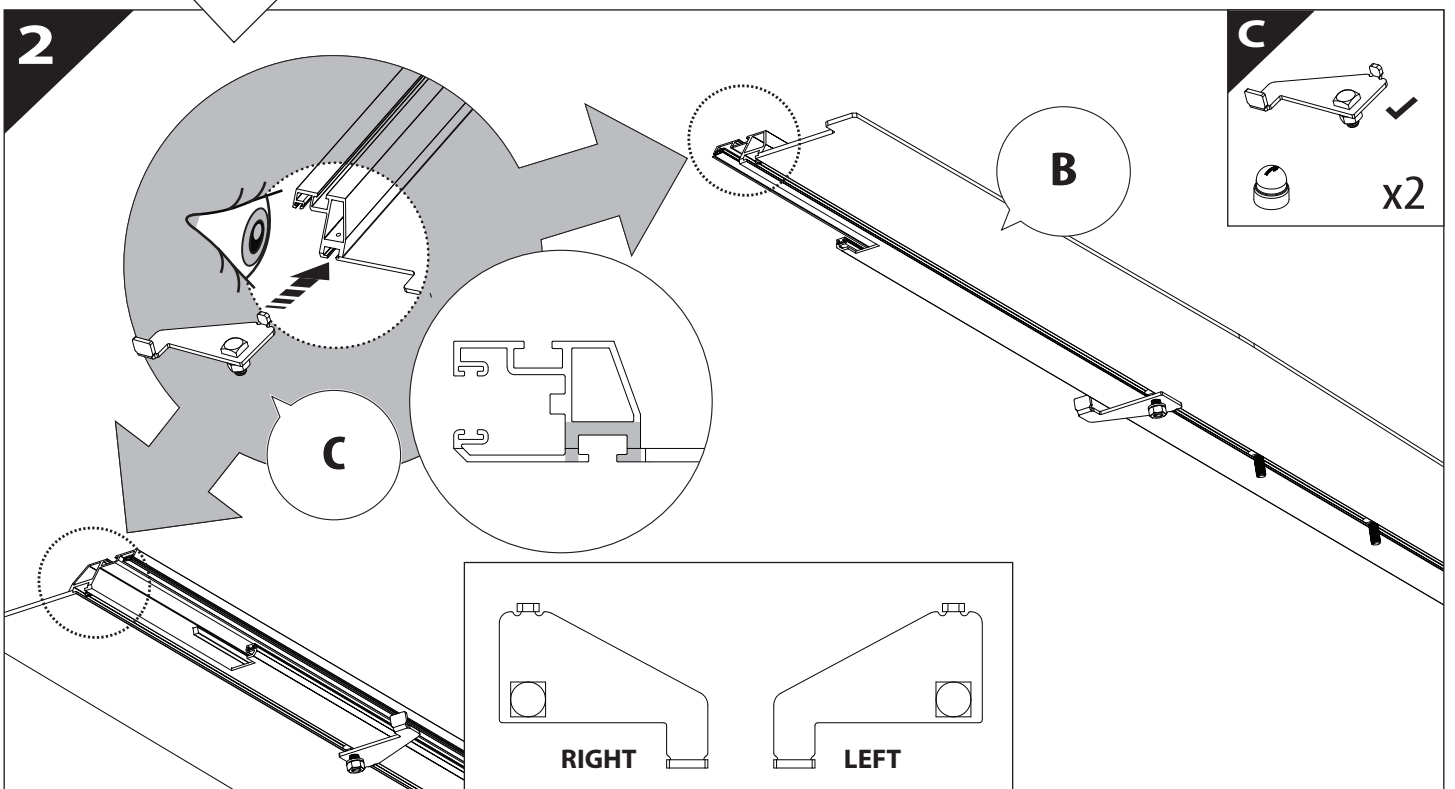
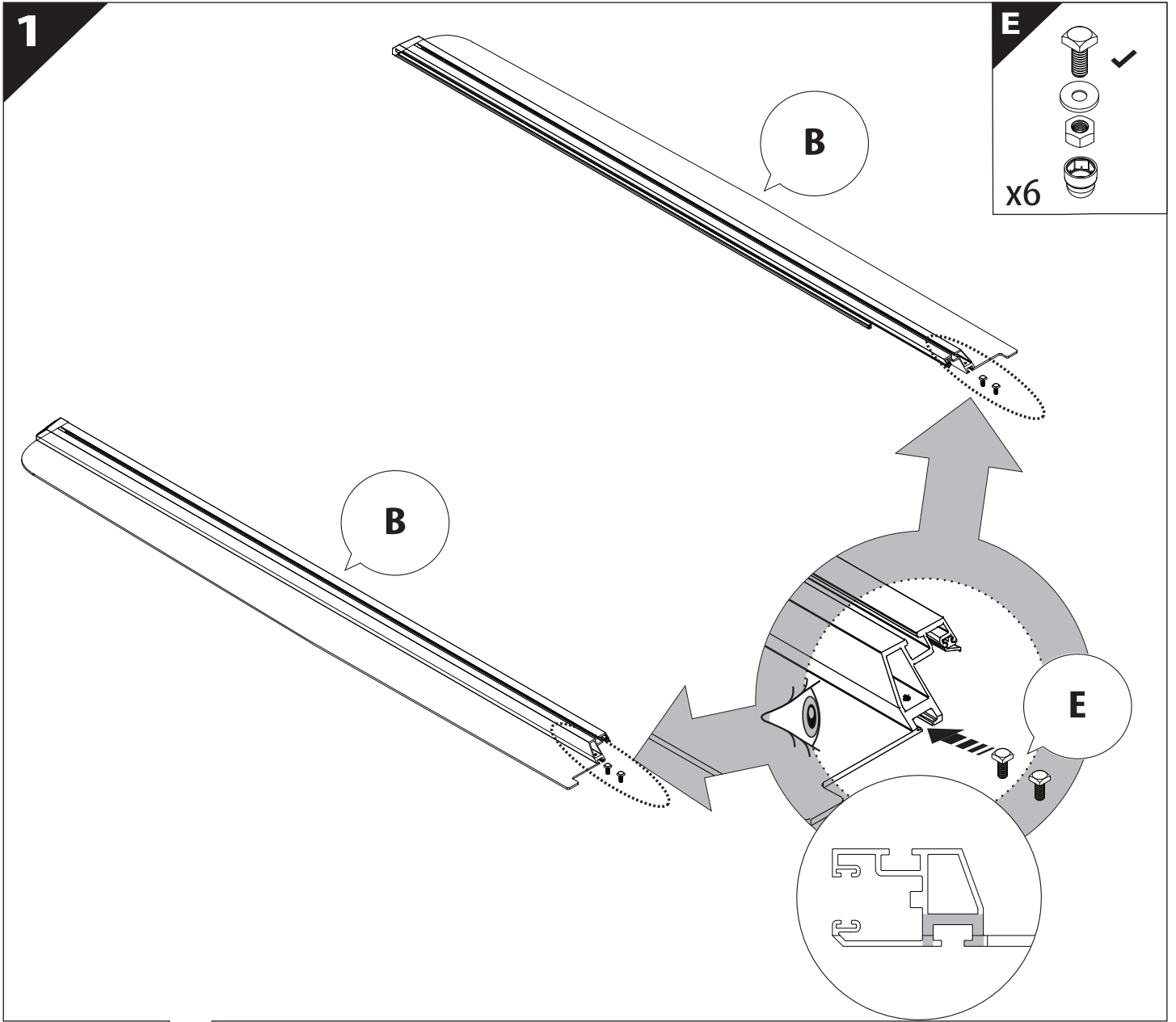

3

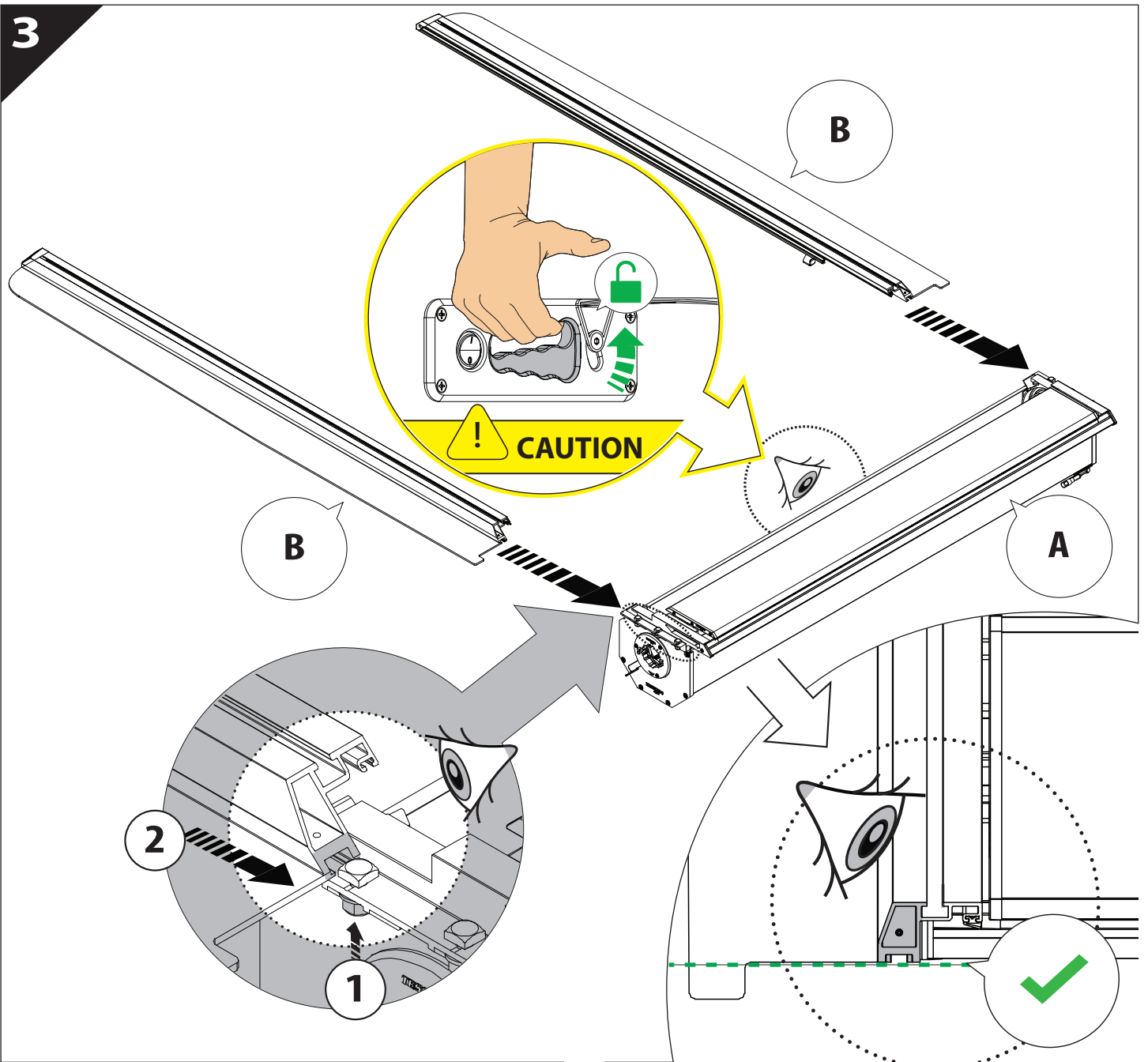

4

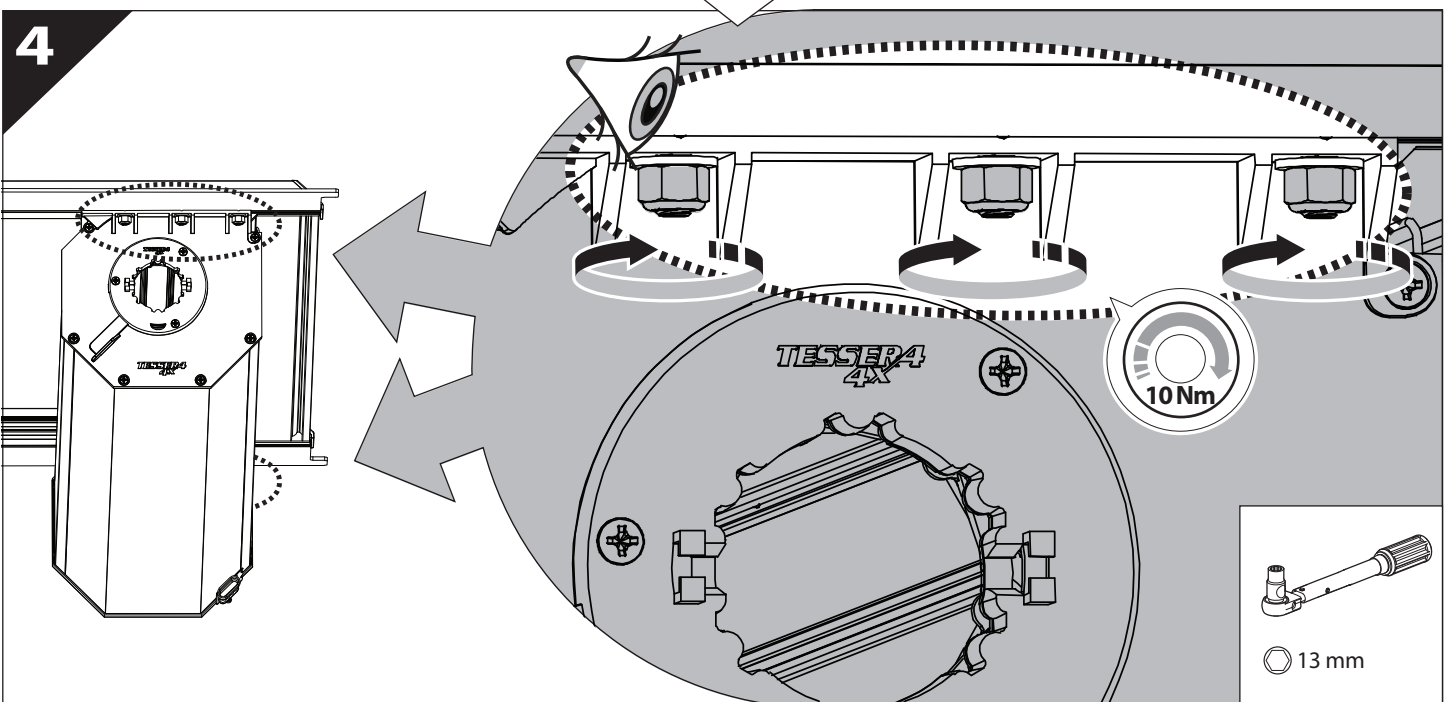

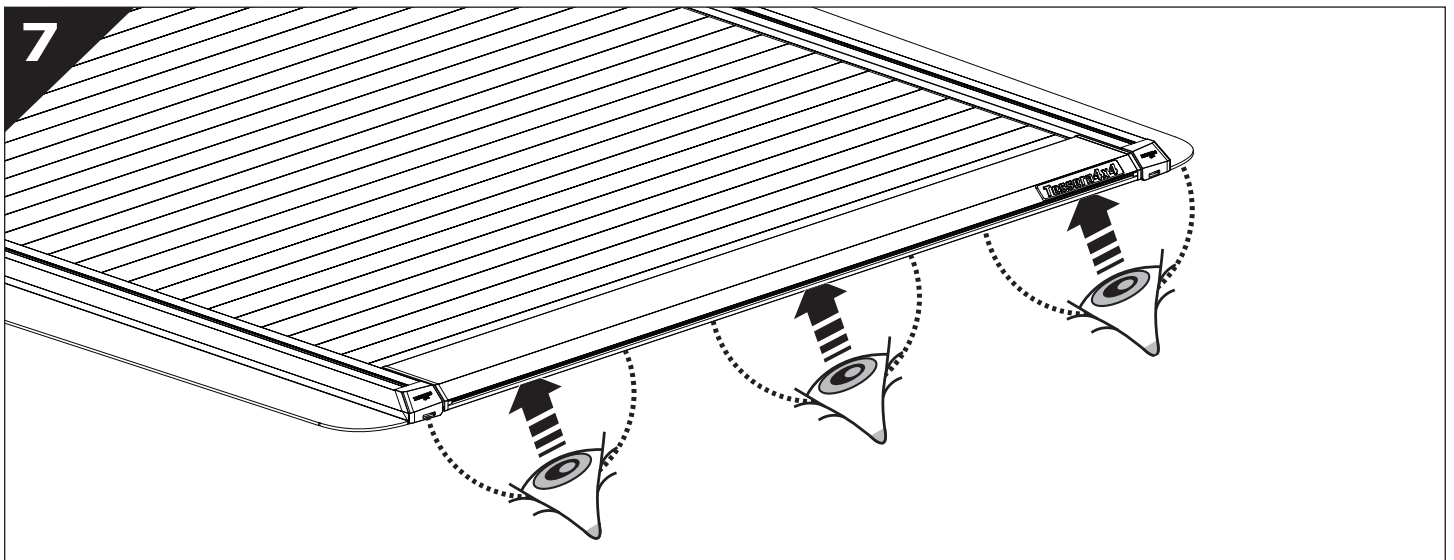
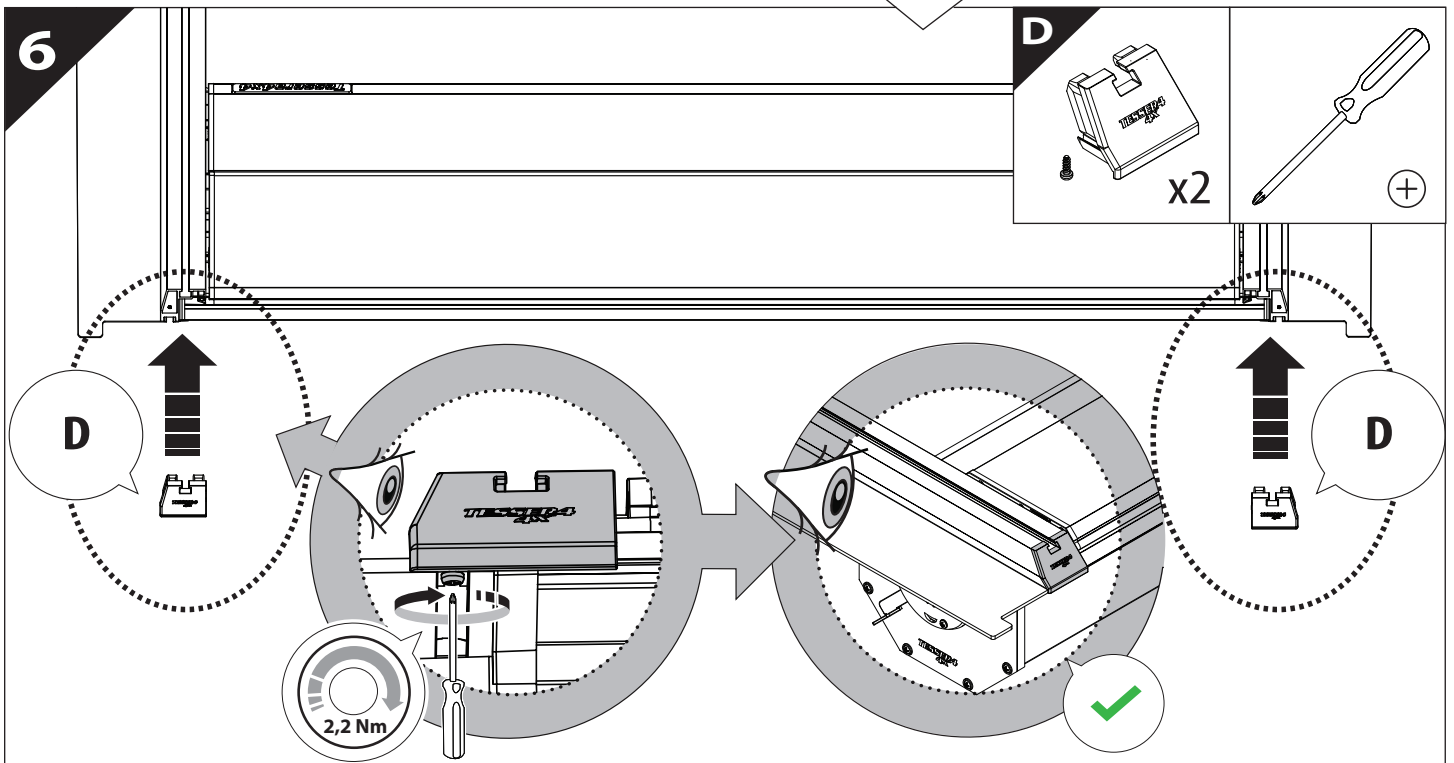
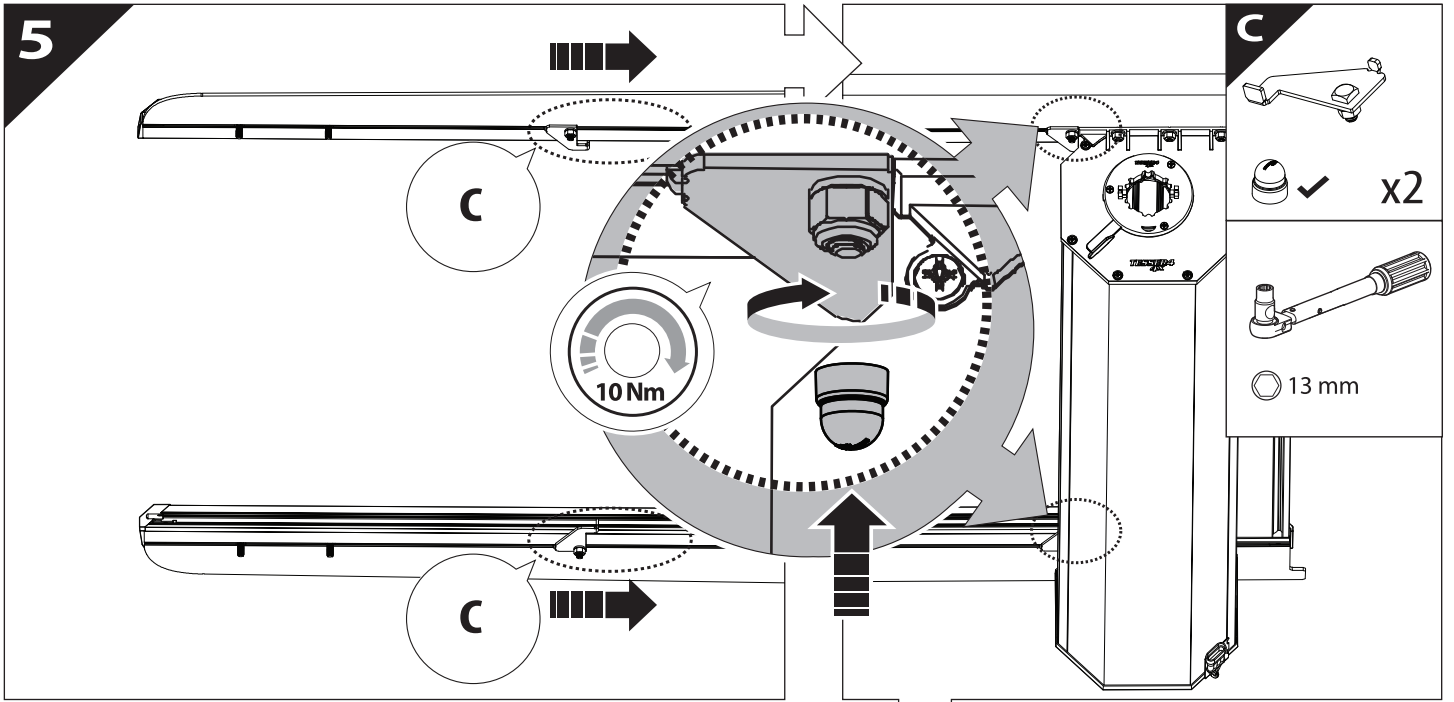

8

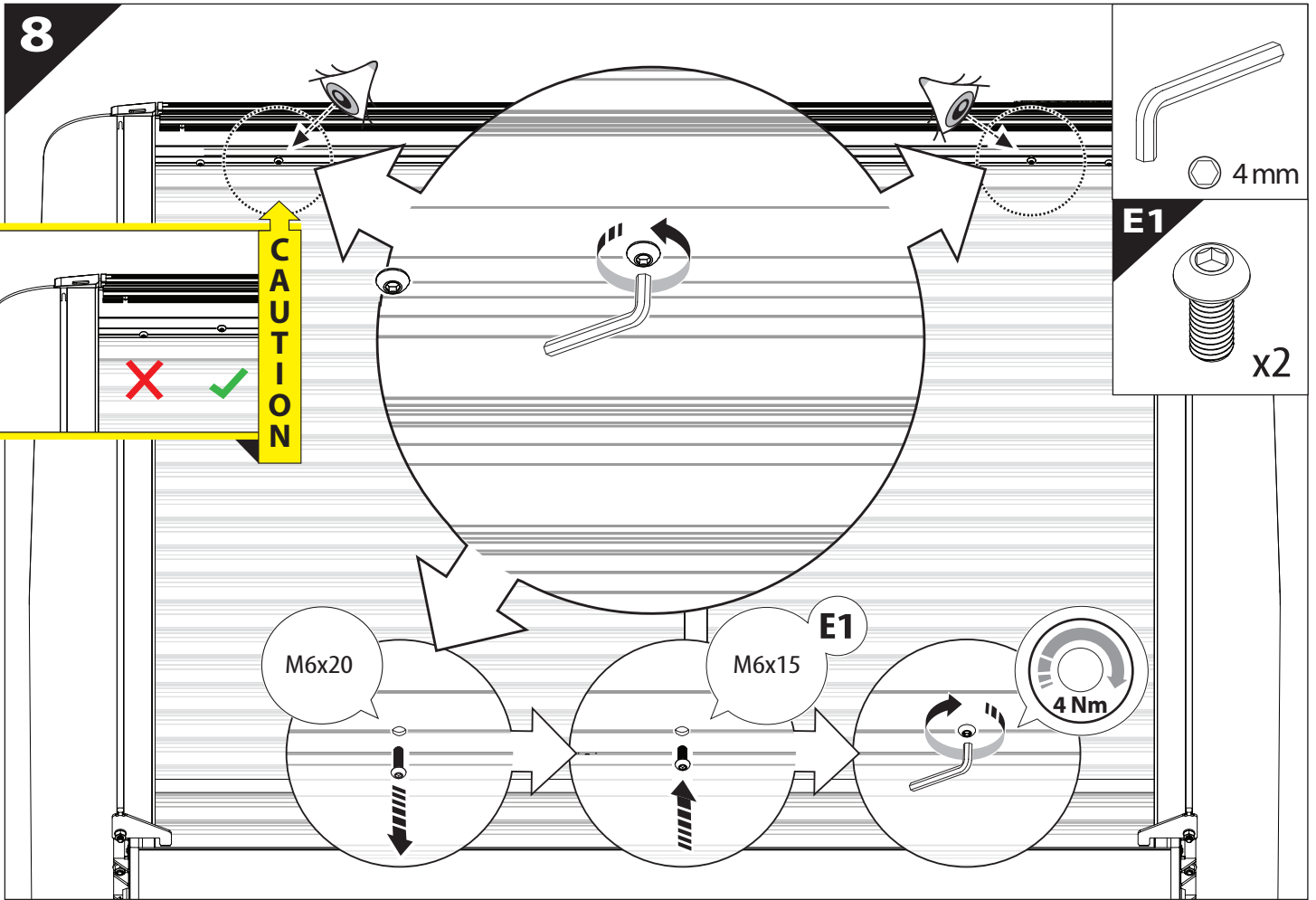
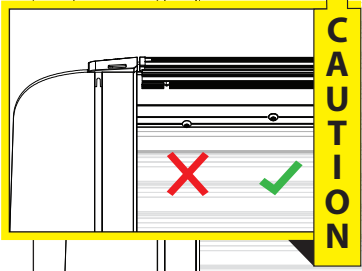

9

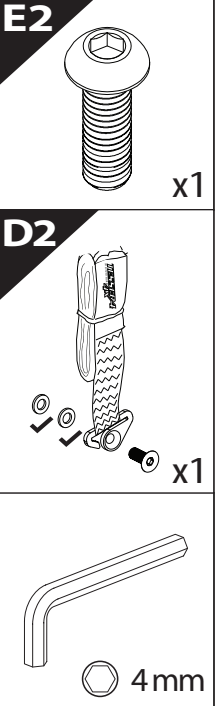
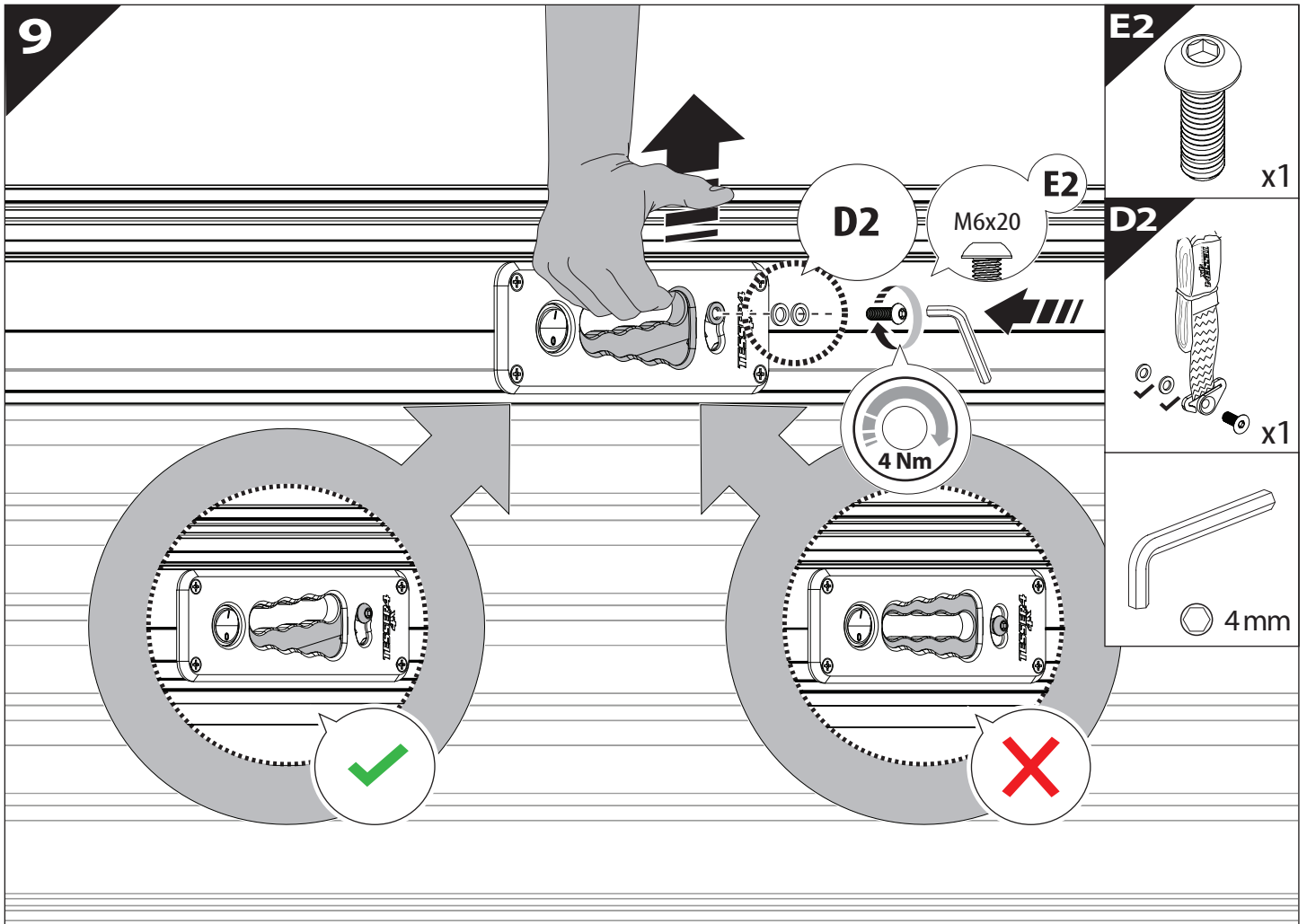

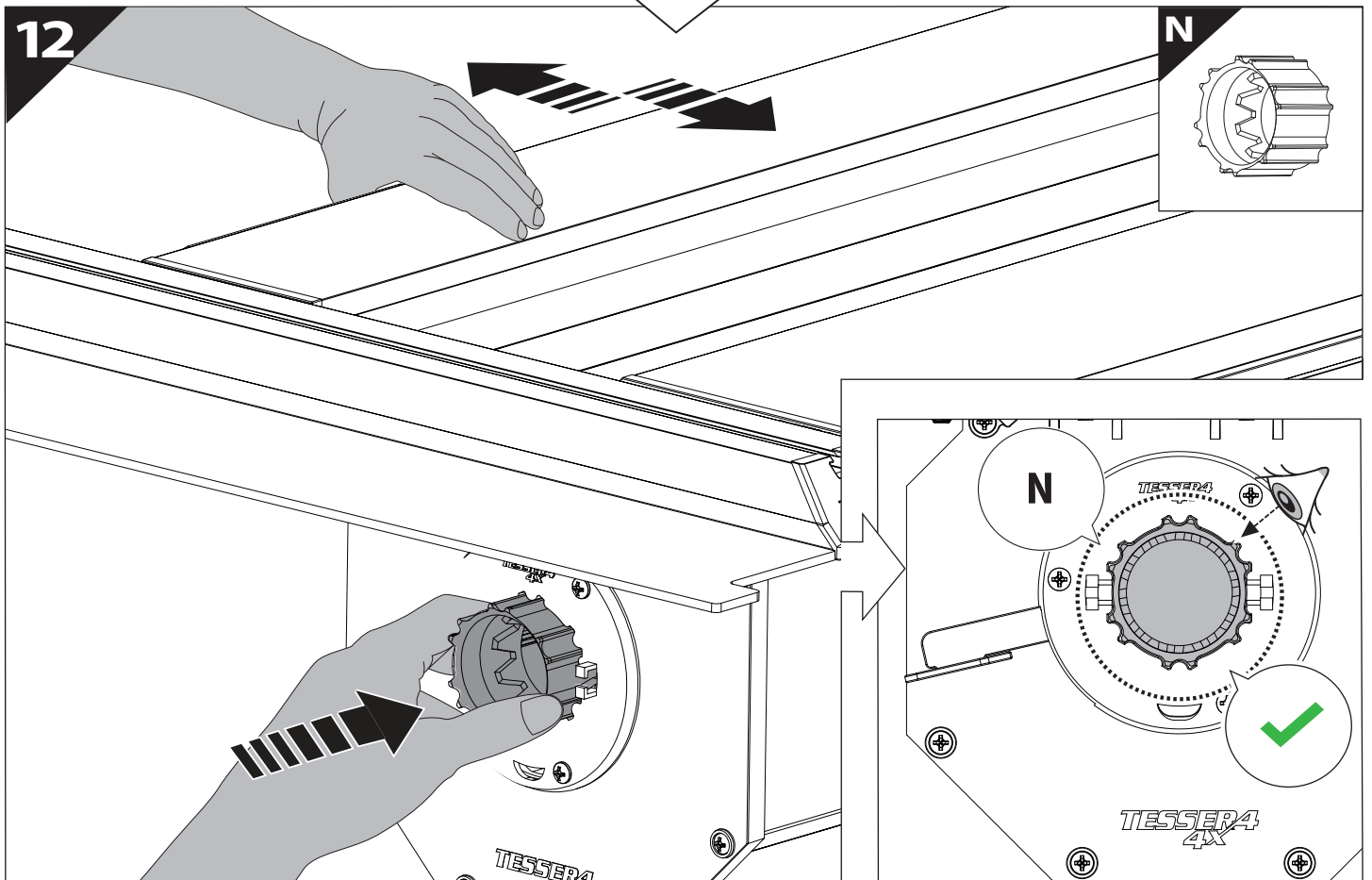
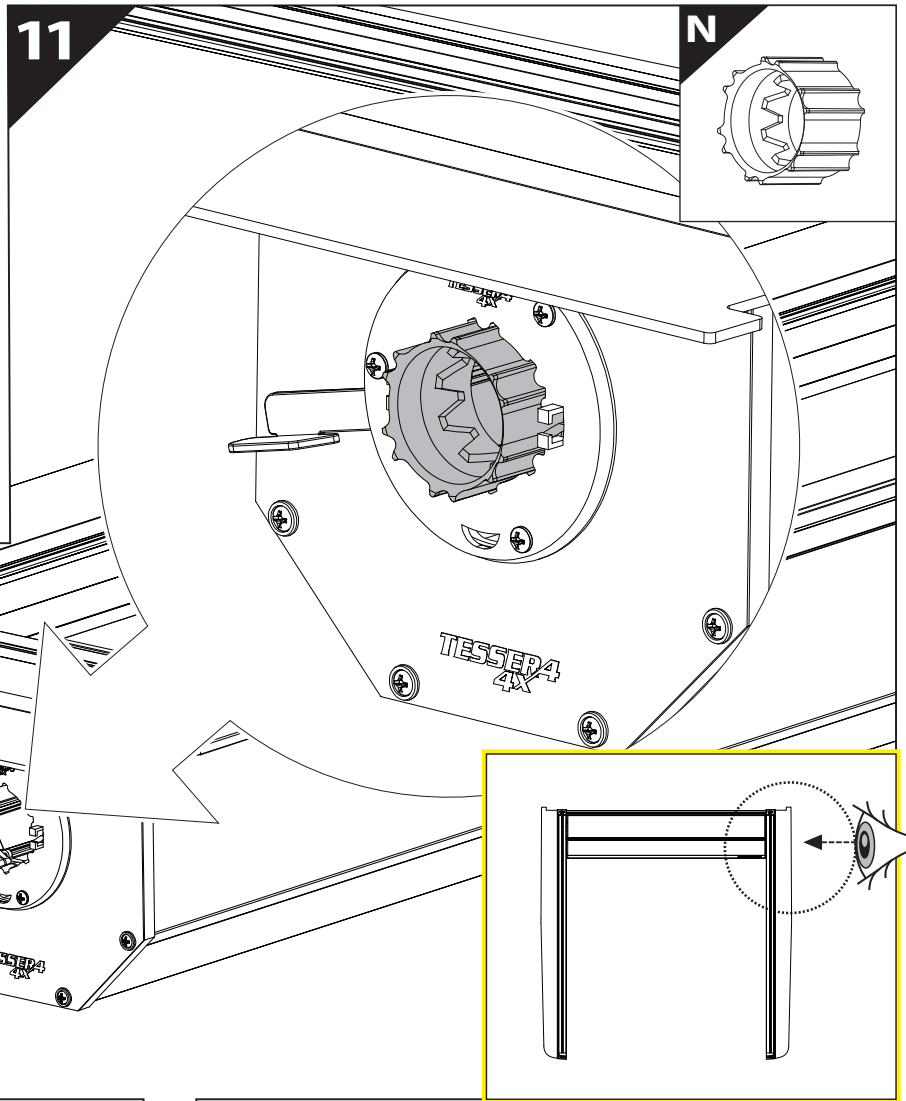
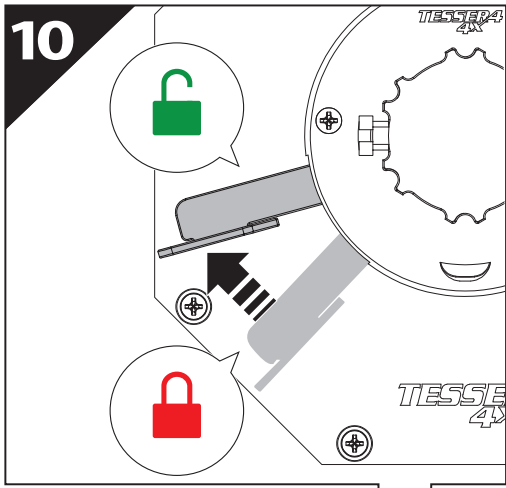

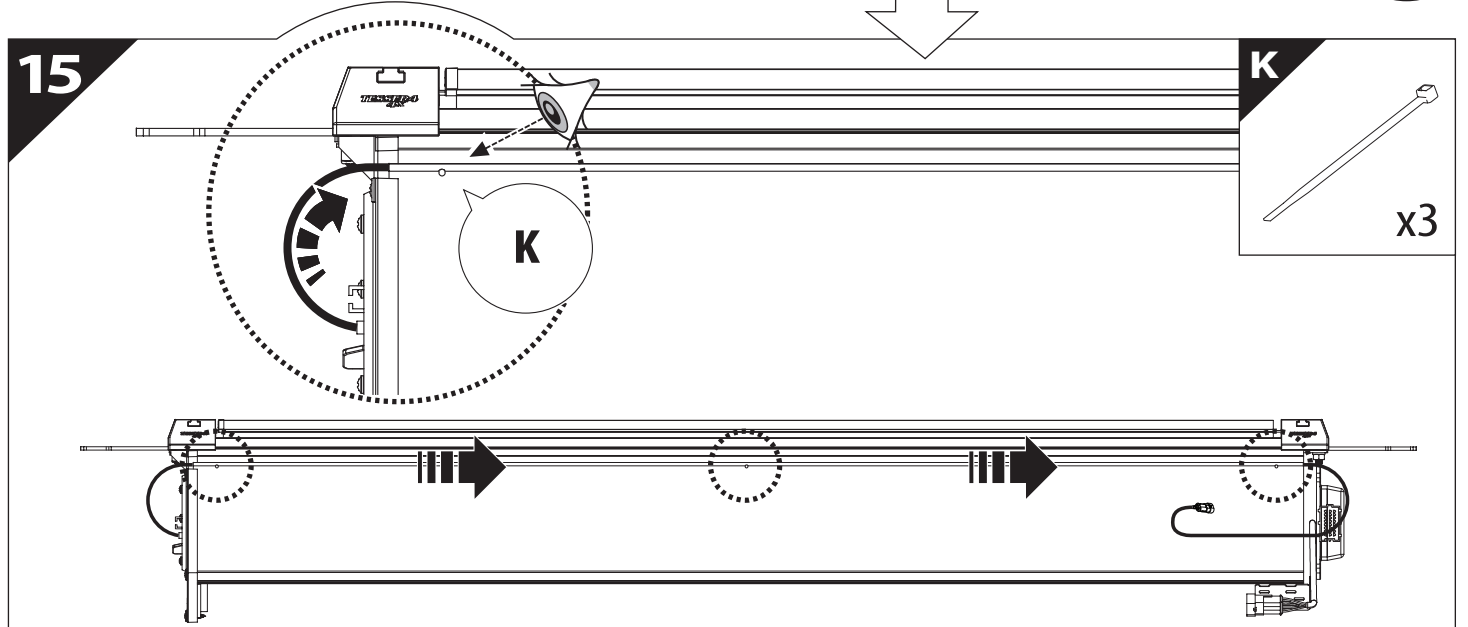
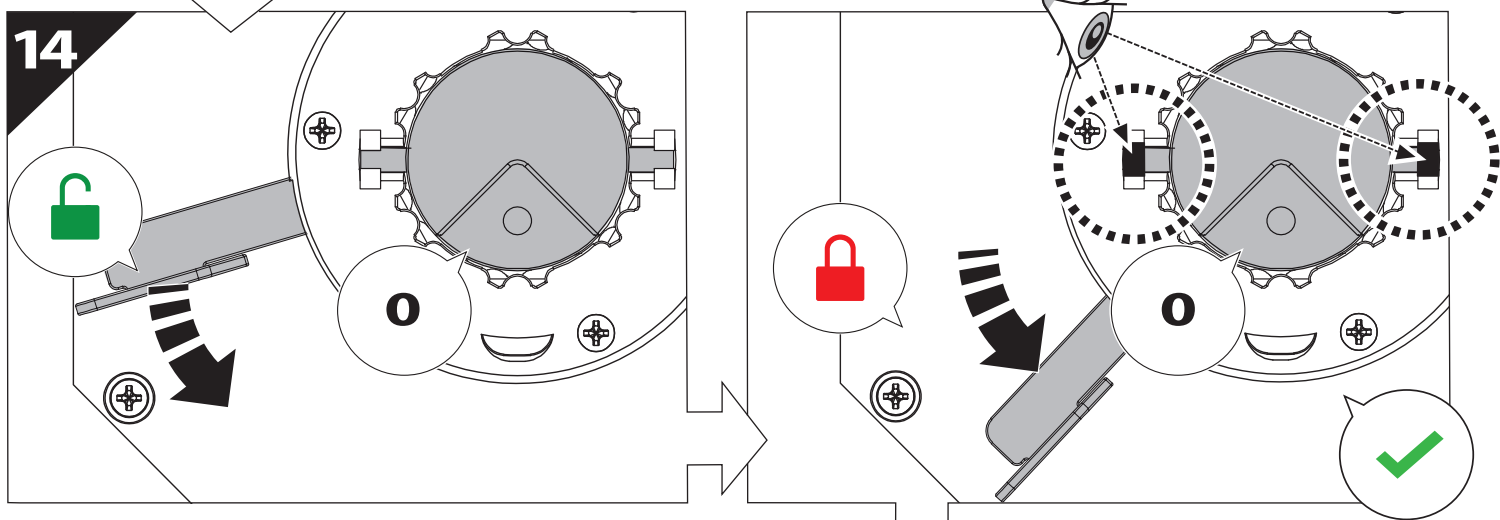
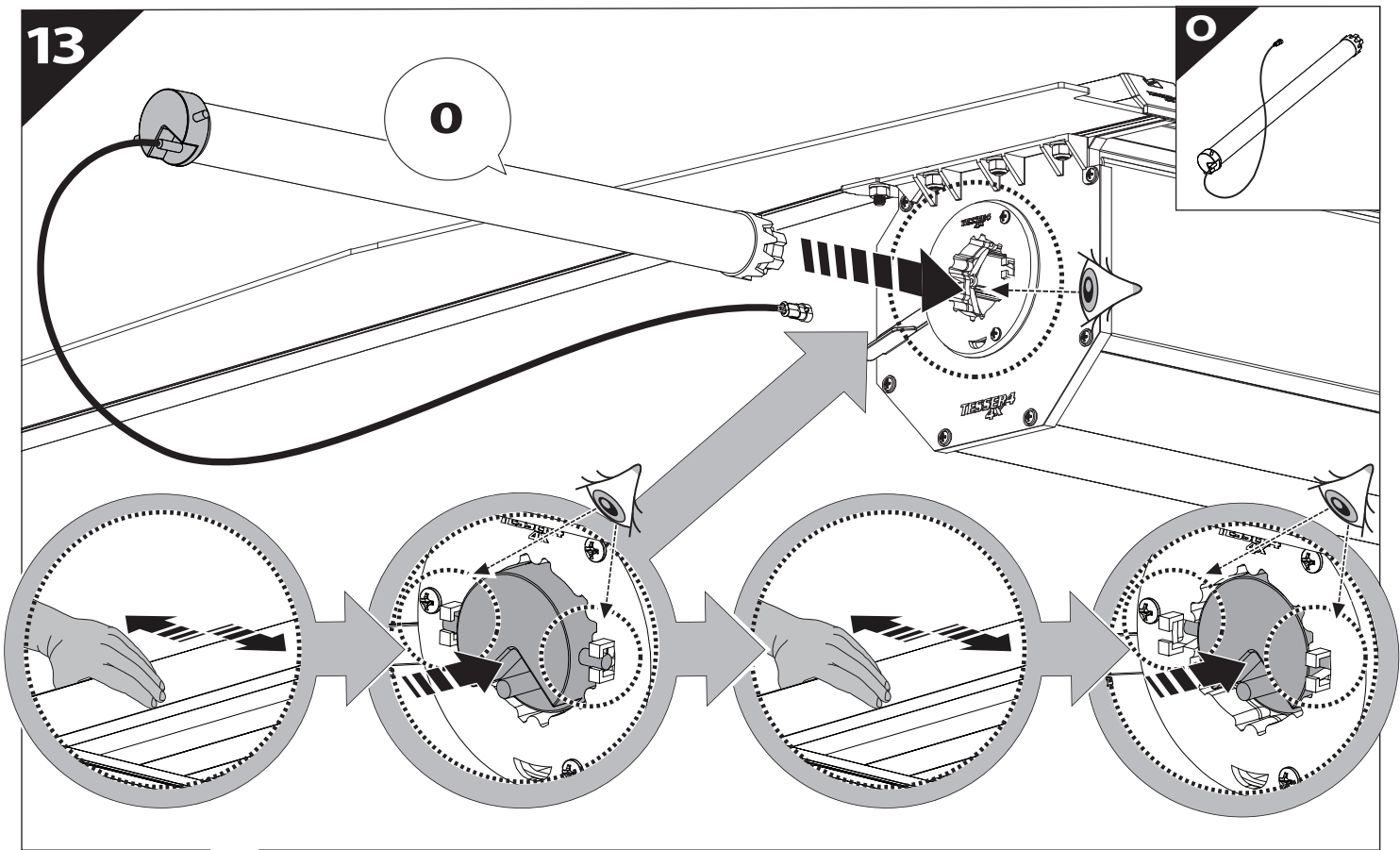

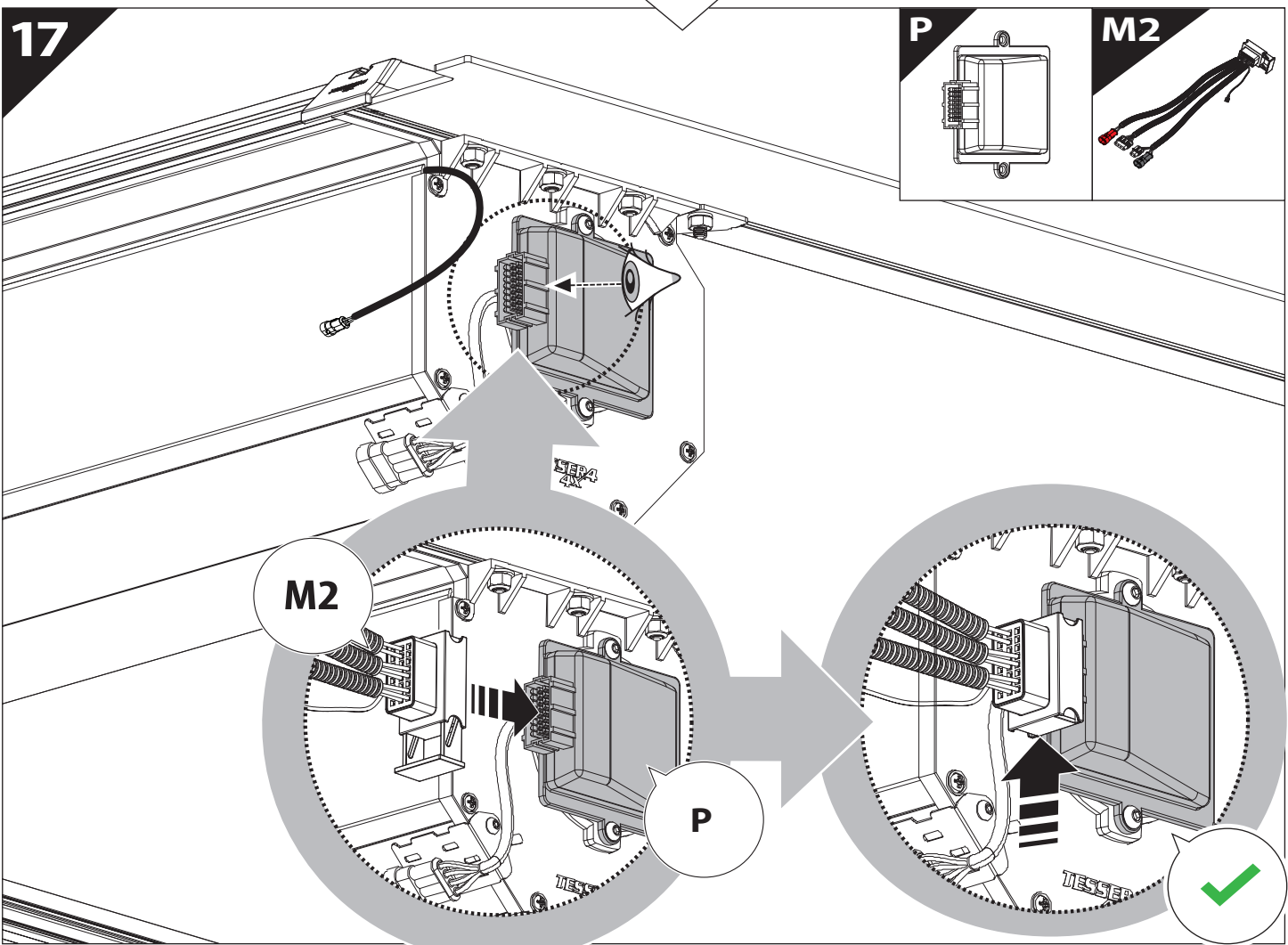
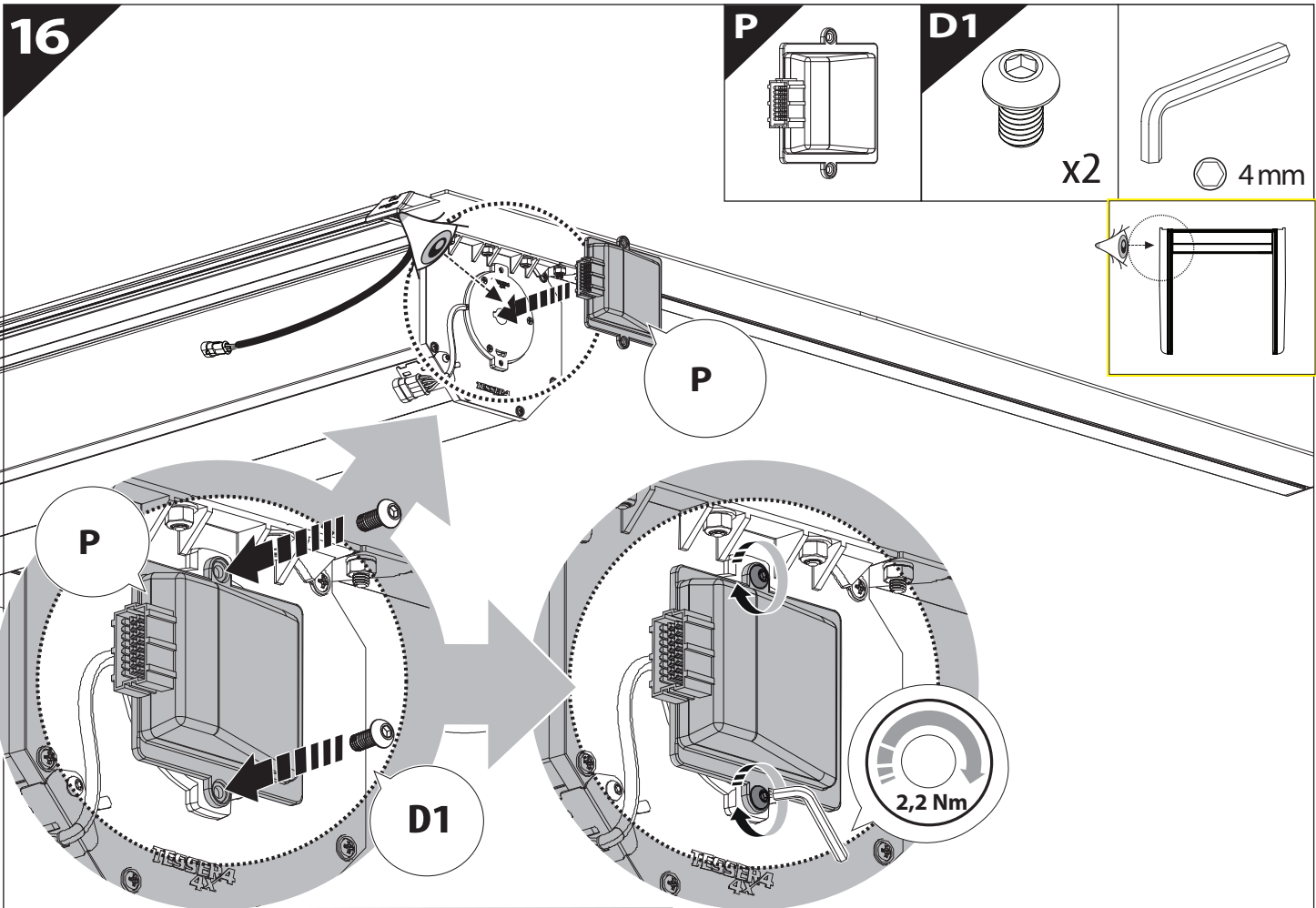

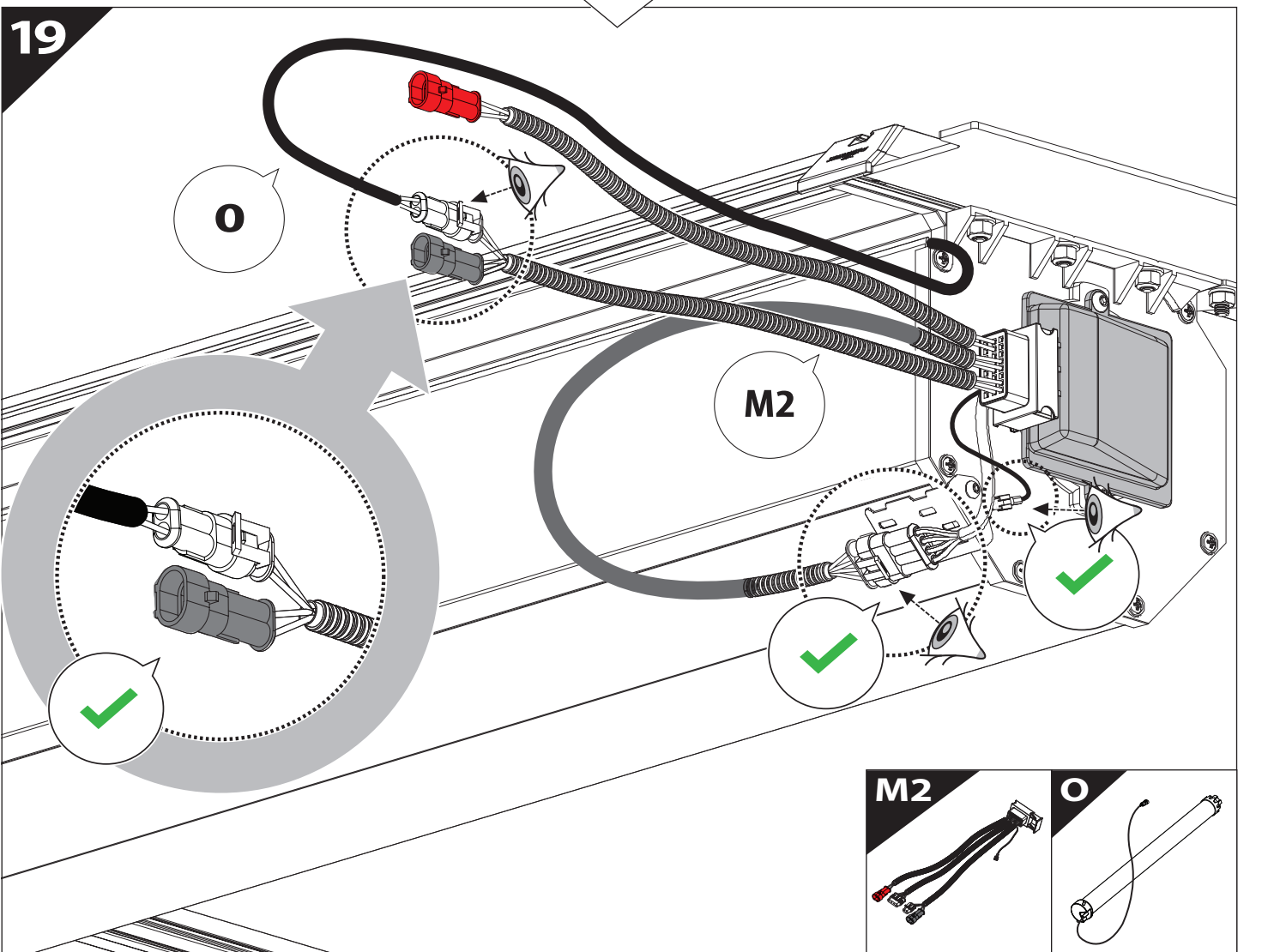
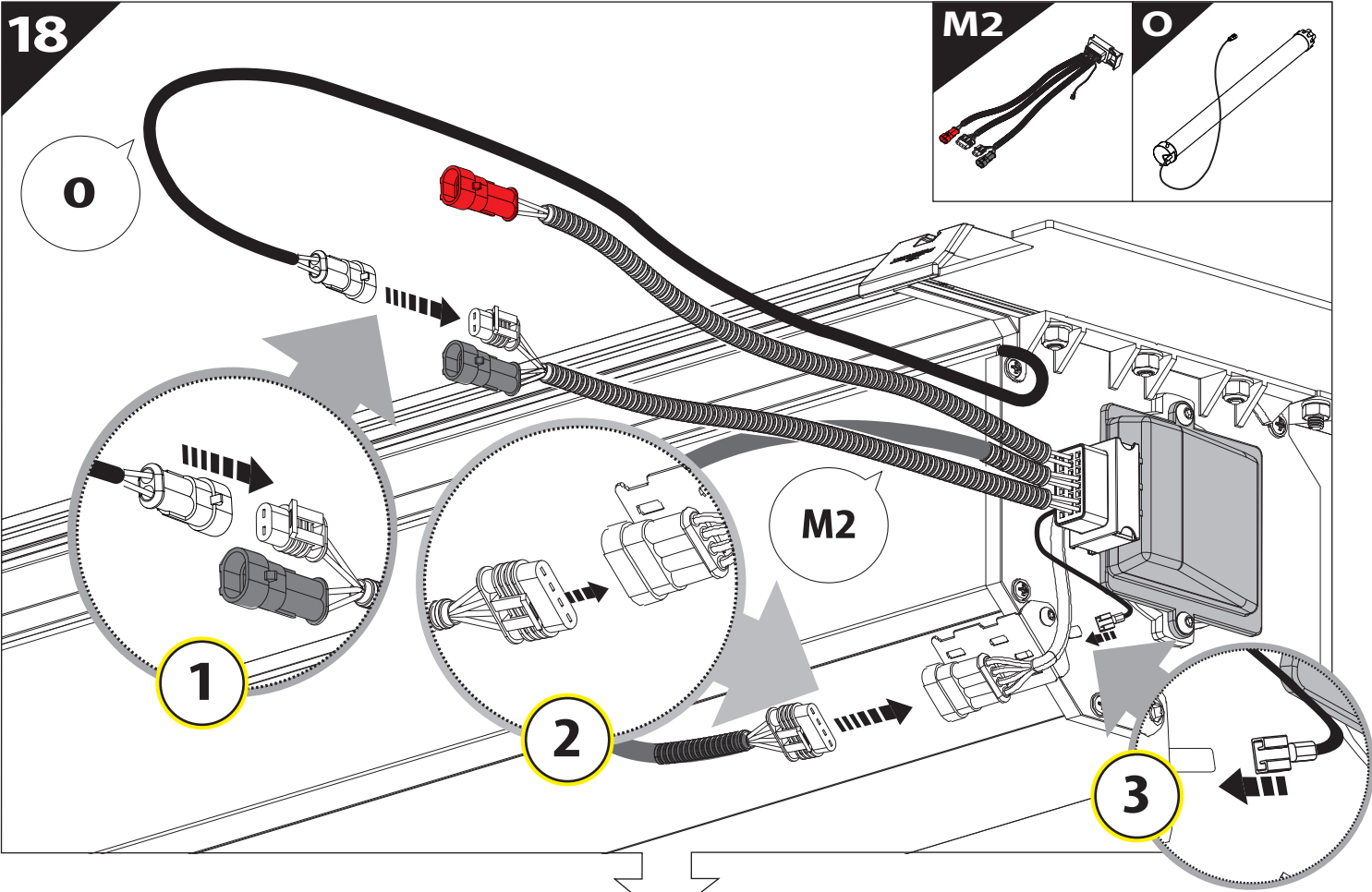

20

K

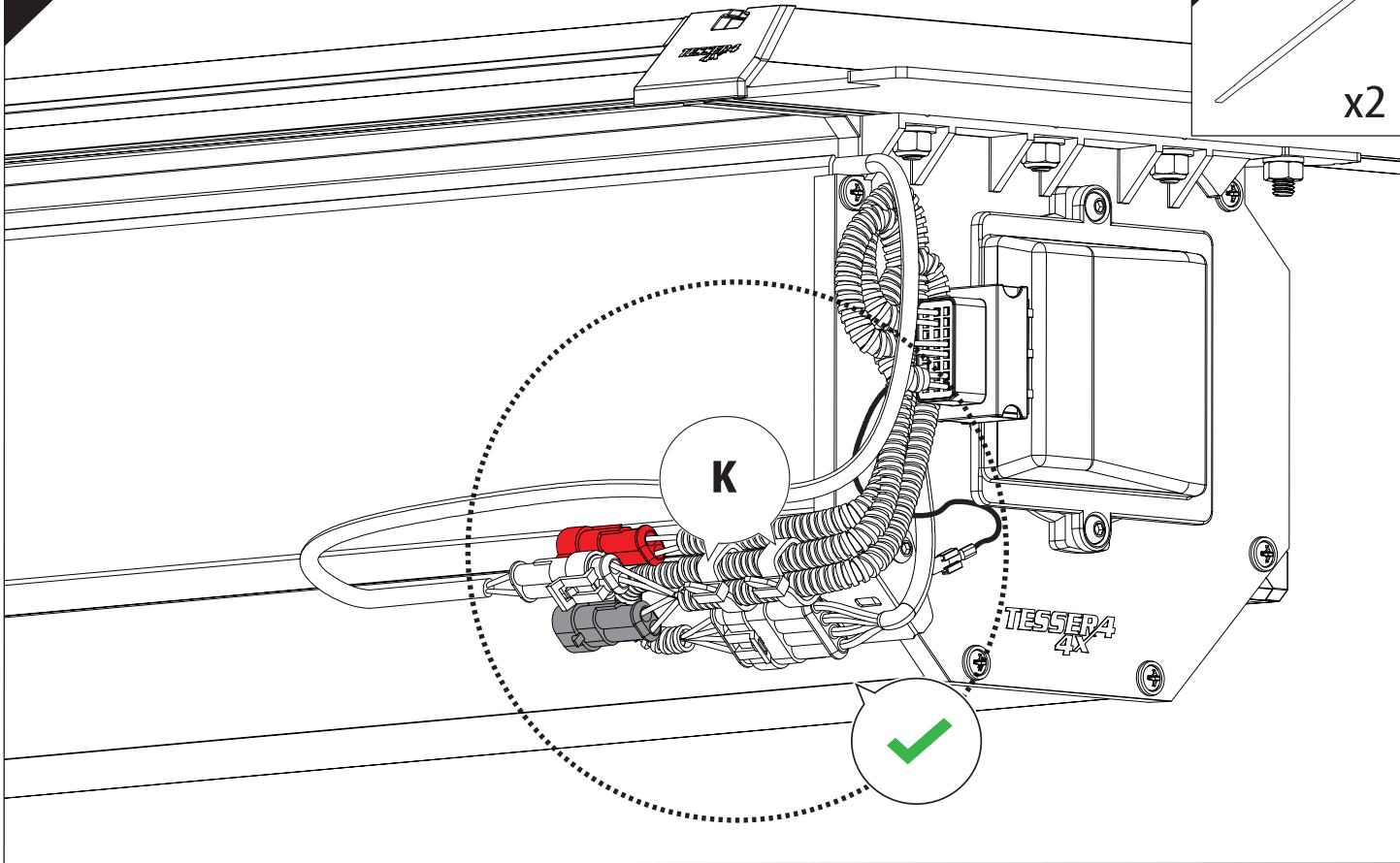
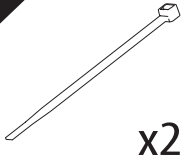

21

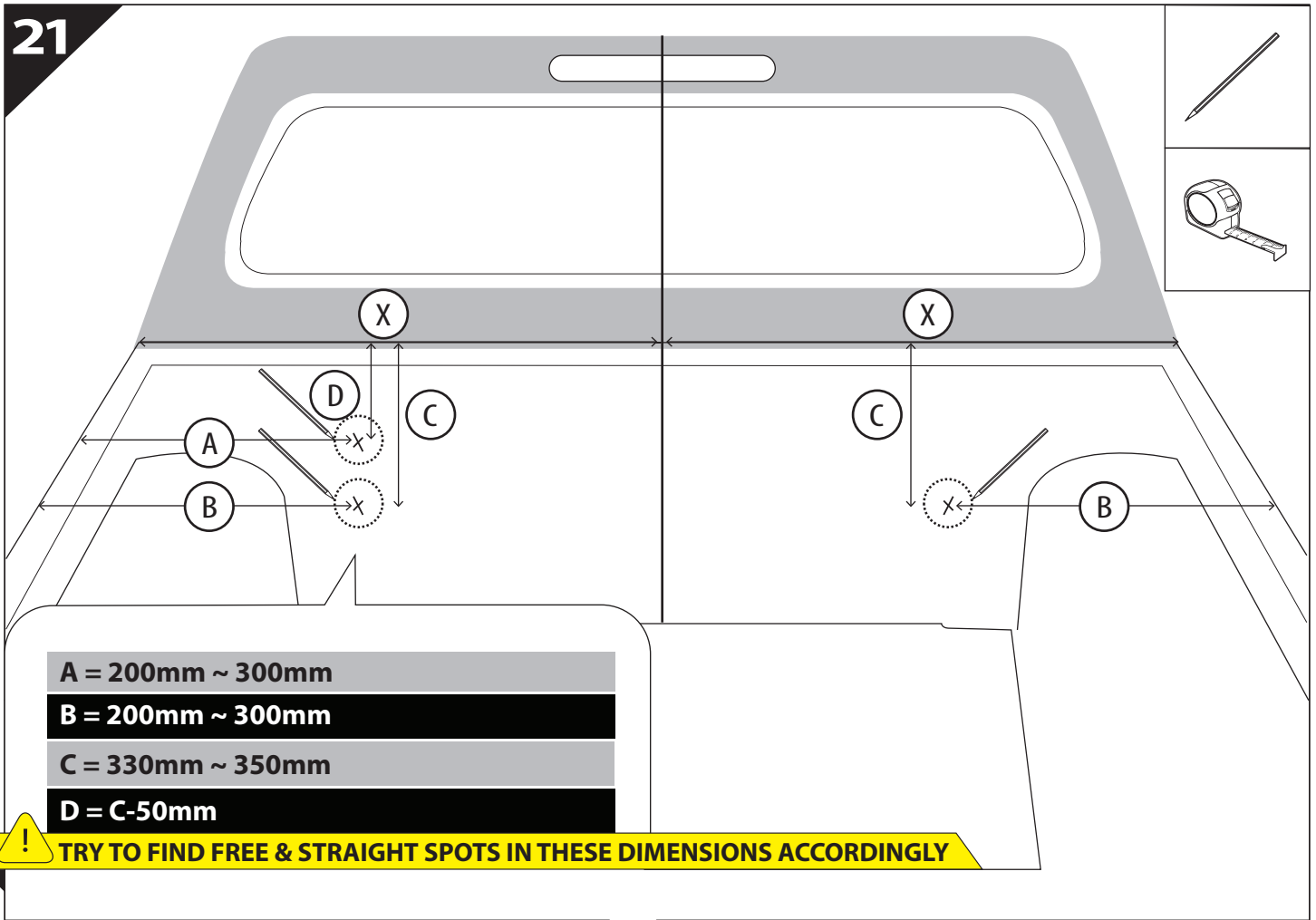

- A = 200mm ~ 300mm
- B = 200mm ~ 300mm
- C = 330mm ~ 350mm
- D = C-50mm

**! TRY TO FIND FREE & STRAIGHT SPOTS IN THESE DIMENSIONS ACCORDINGLY**

22

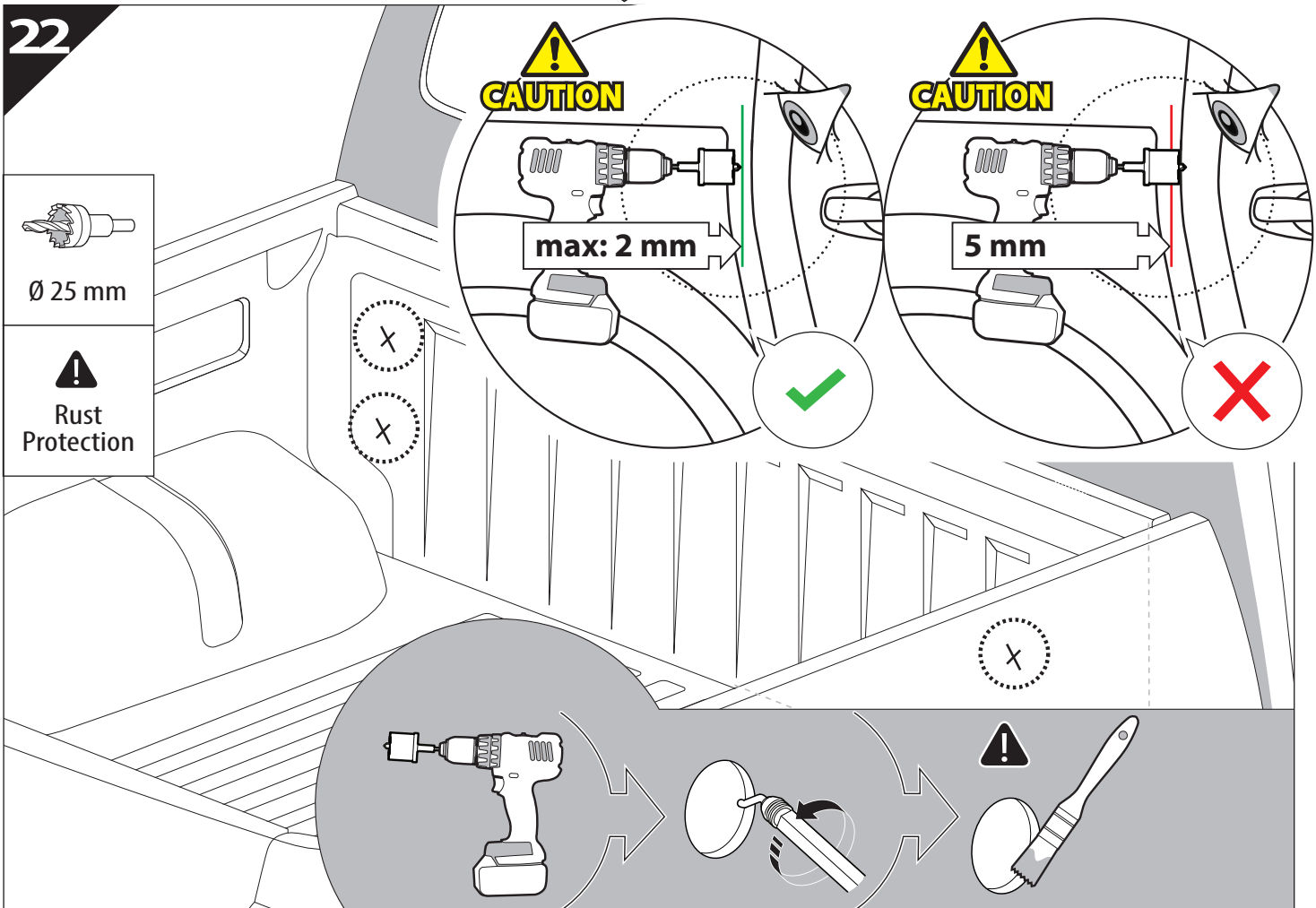

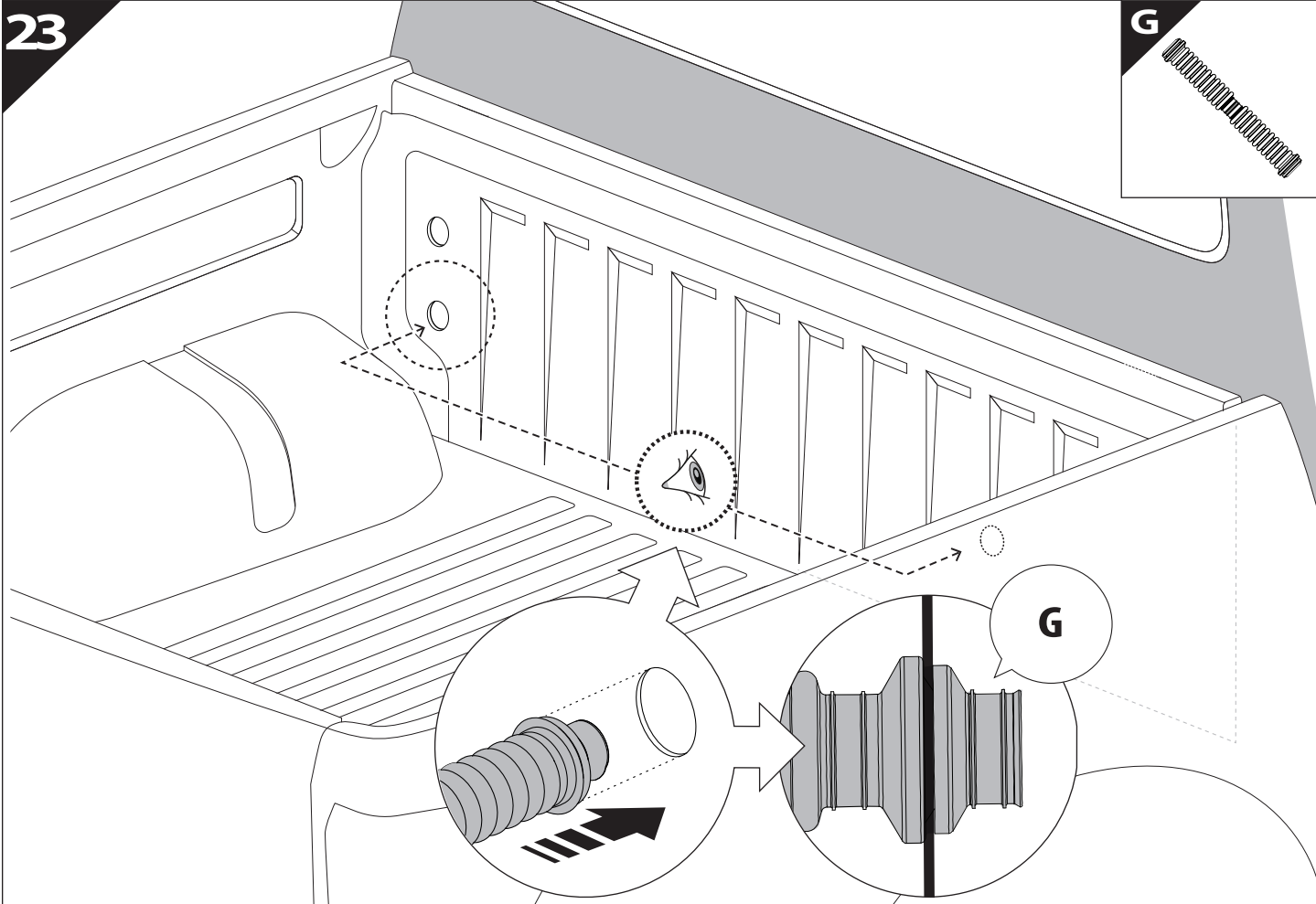

**24** Only to be installed by authorized personnel

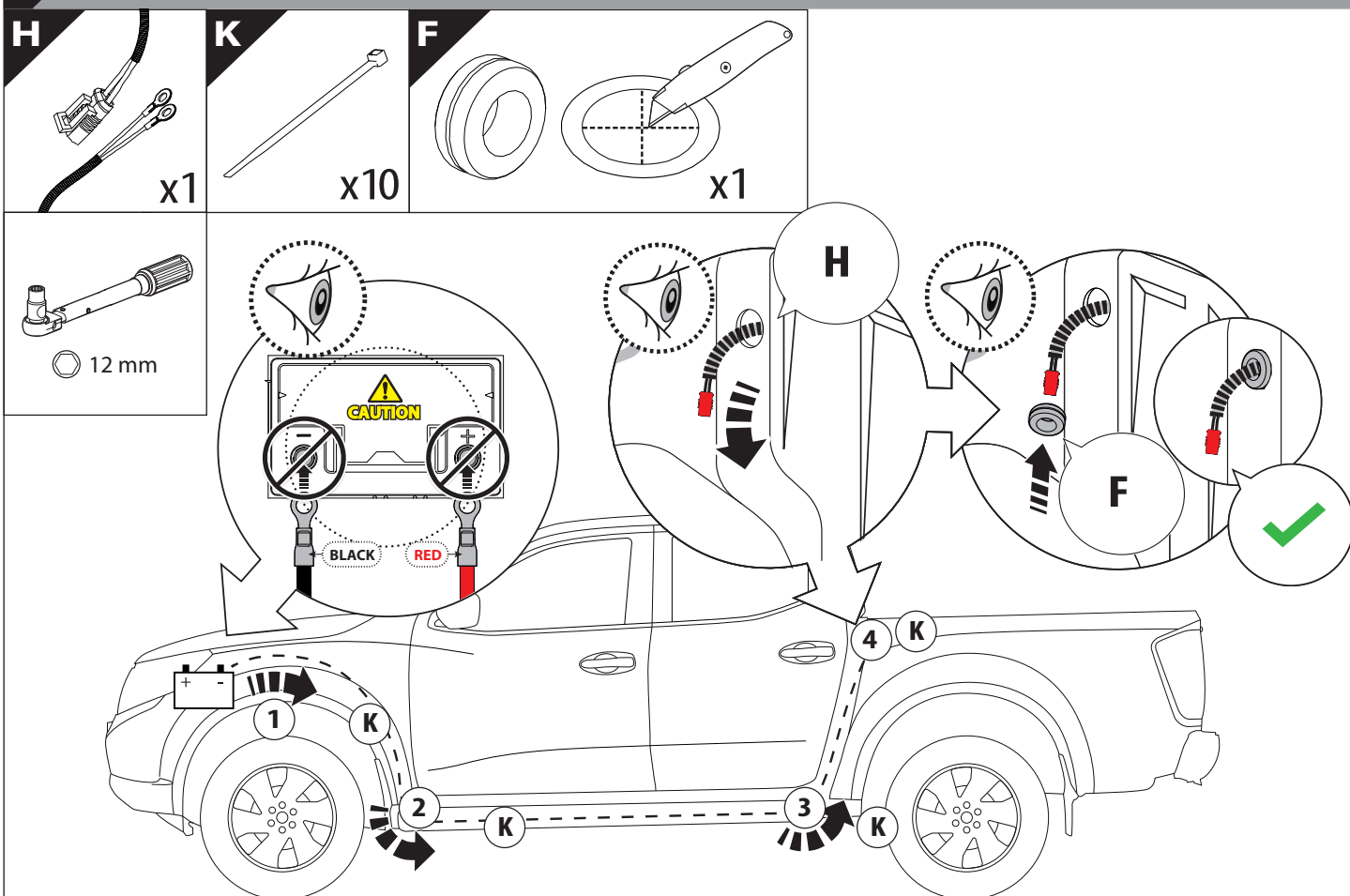

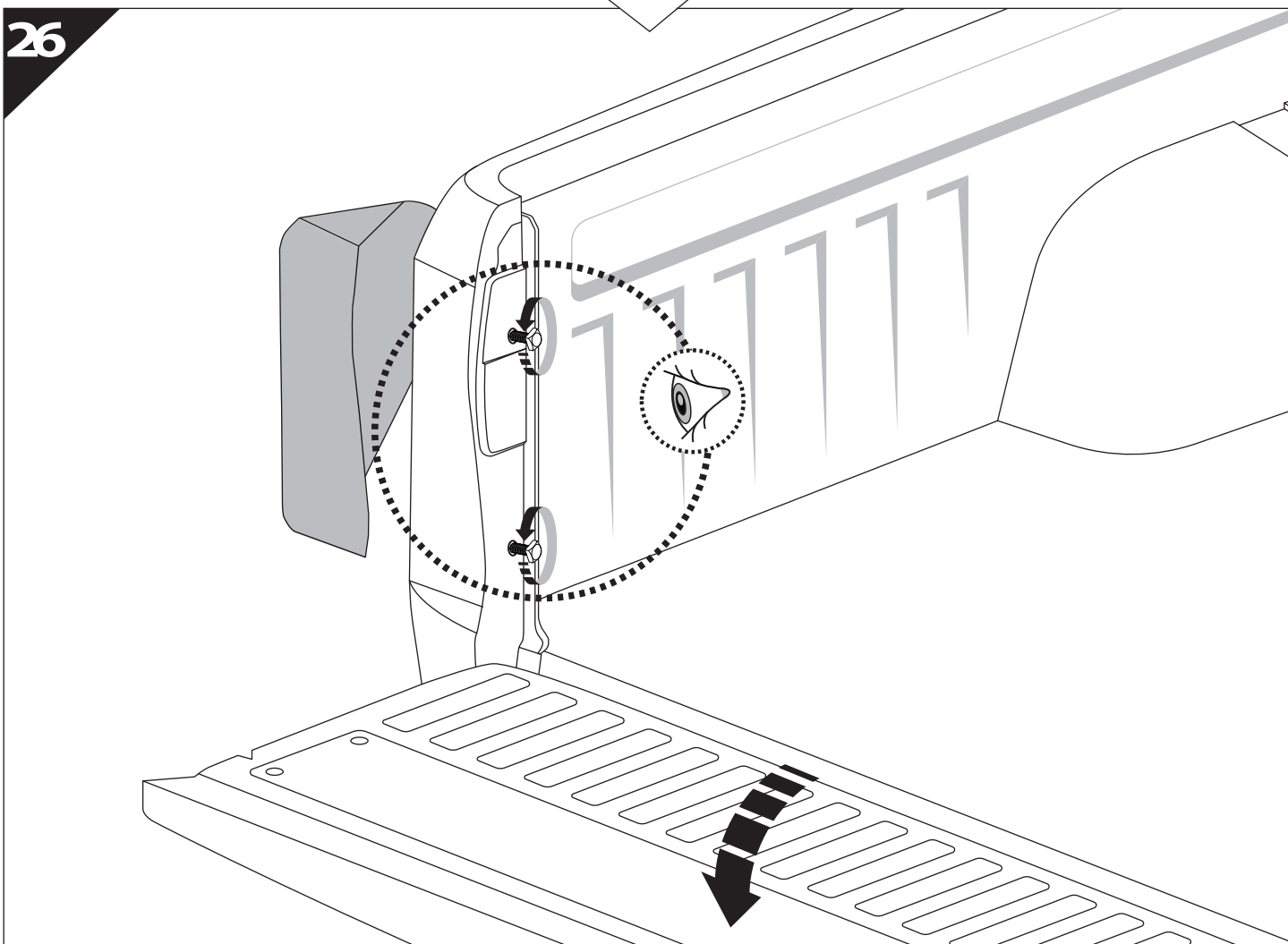
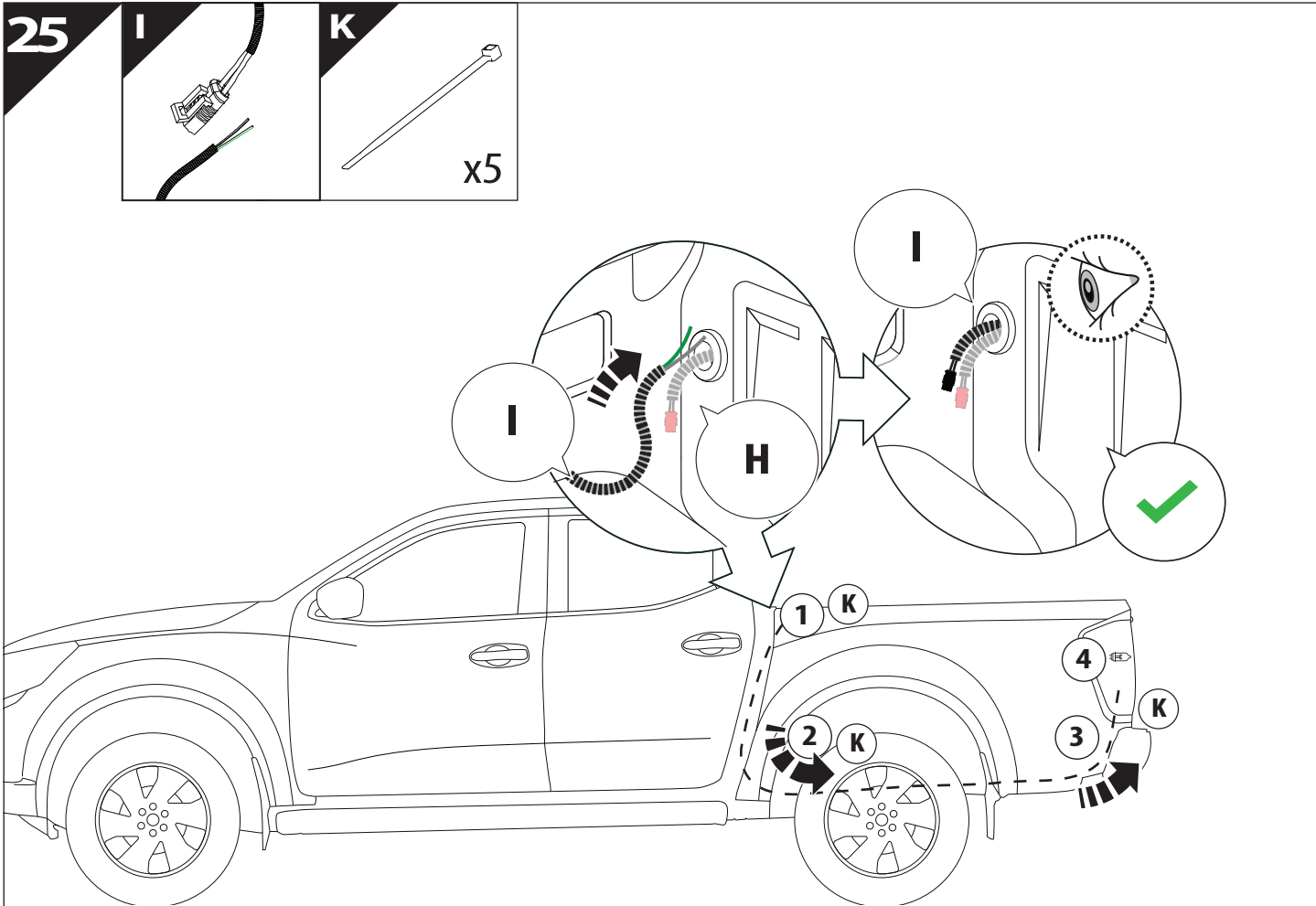

27

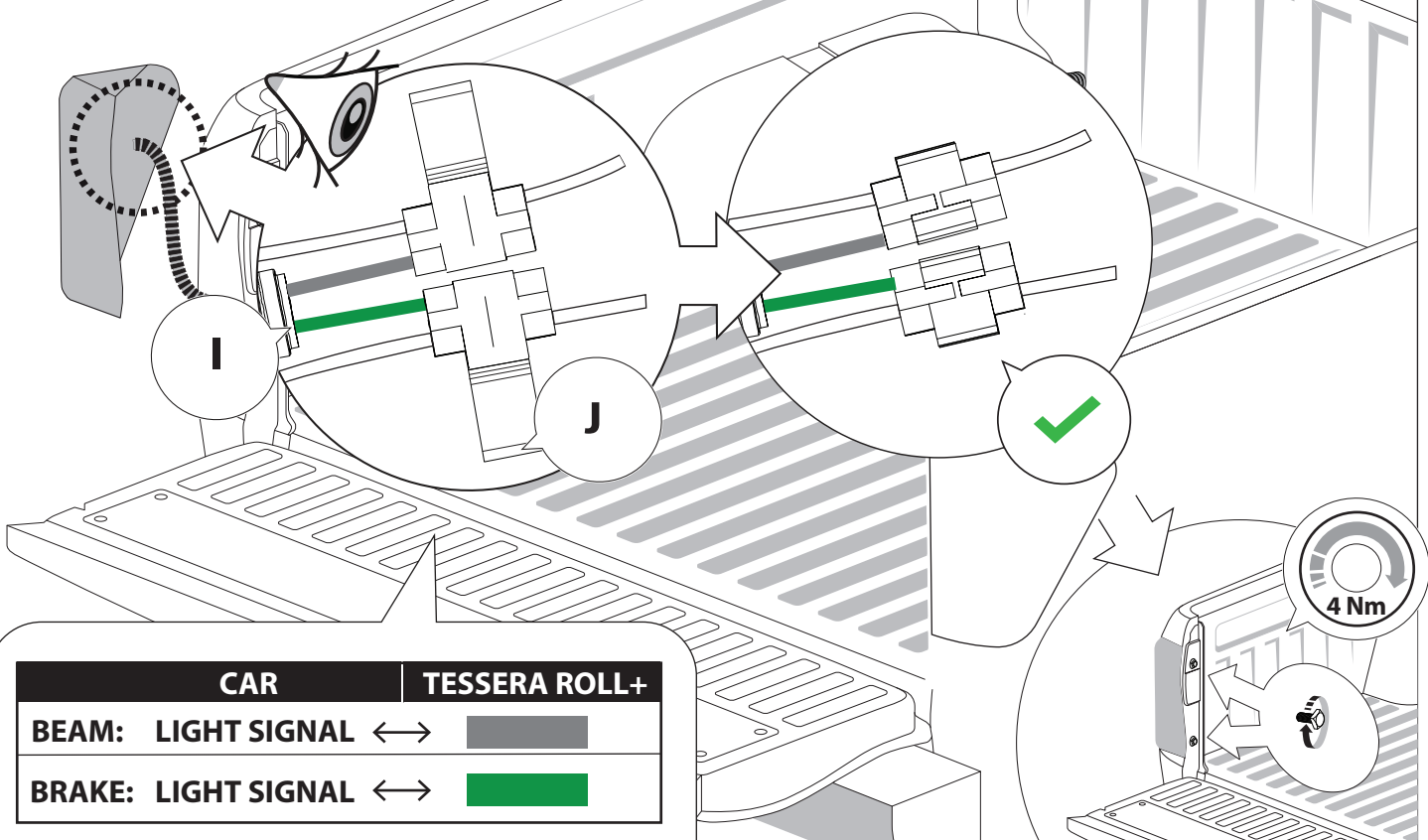
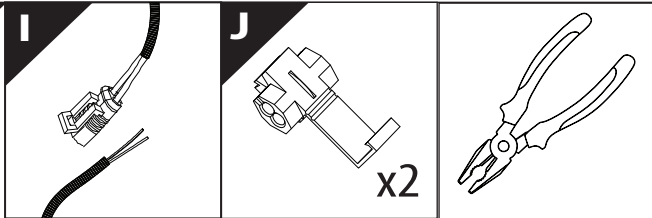

CAR	TESSERA ROLL+
BEAM: LIGHT SIGNAL ↔	
BRAKE: LIGHT SIGNAL ↔	

**CAUTION: CONSULT A CERTIFIED AUTO MECHANIC OR AUTOMOTIVE ELECTRICIAN TO IDENTIFY THE CORRECT WIRING CABLES FOR BEAM AND BRAKE SIGNALS BEFORE MAKING ANY CONNECTIONS.**

28

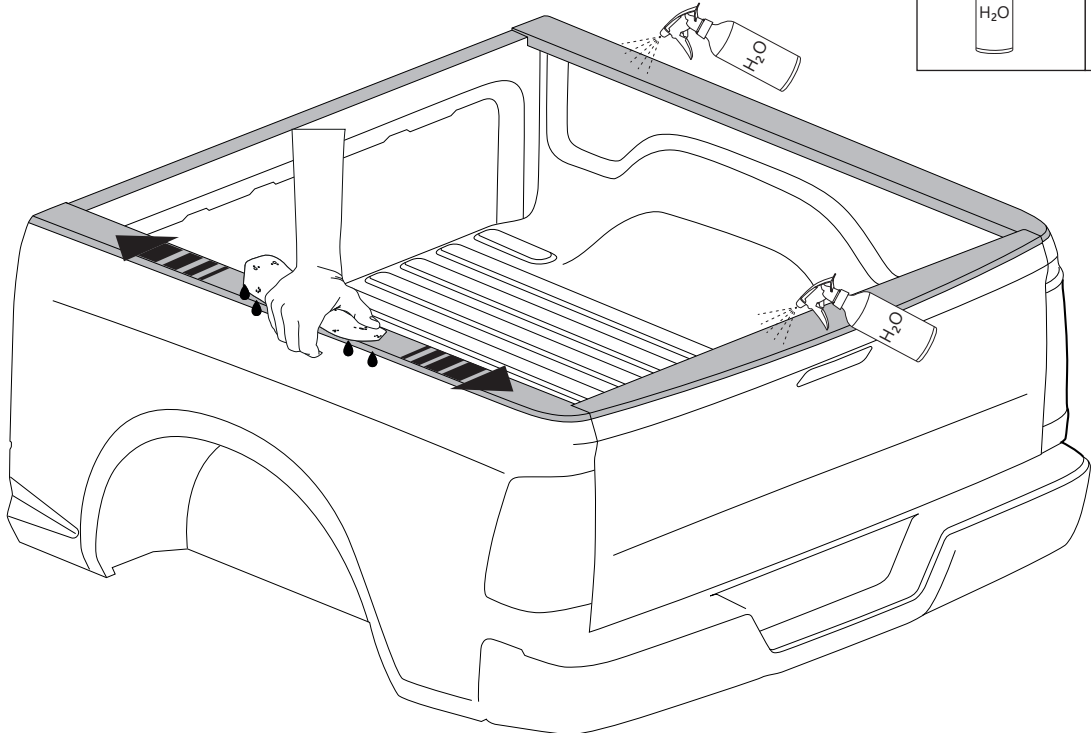
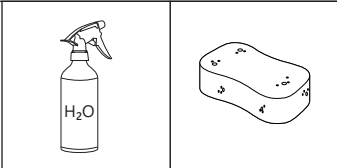

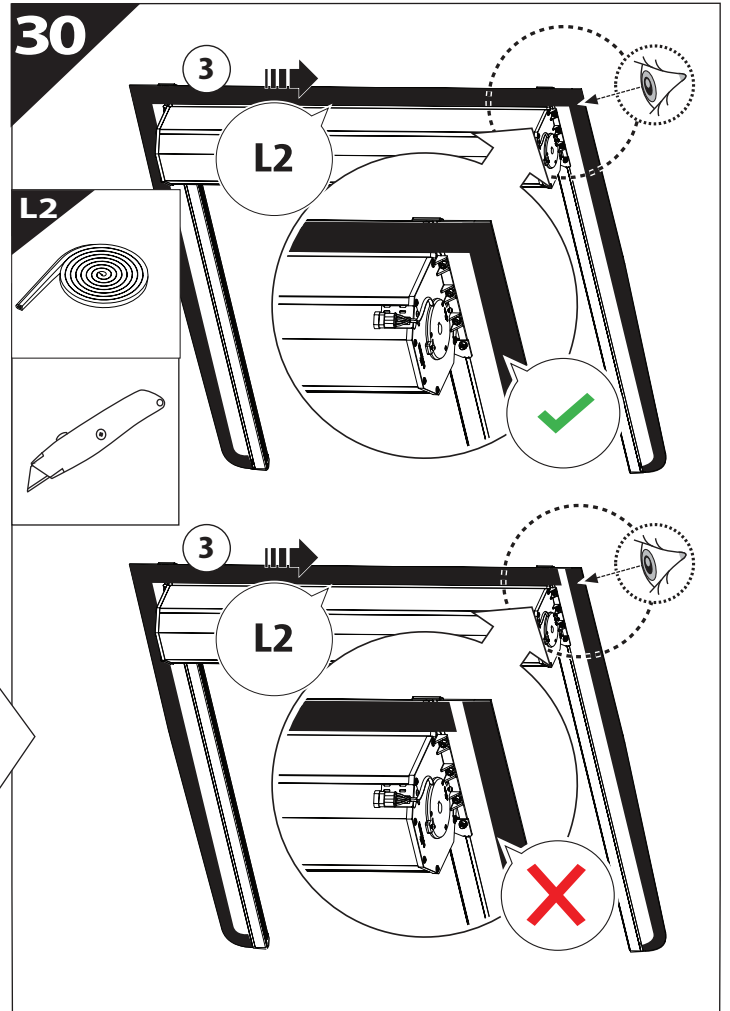
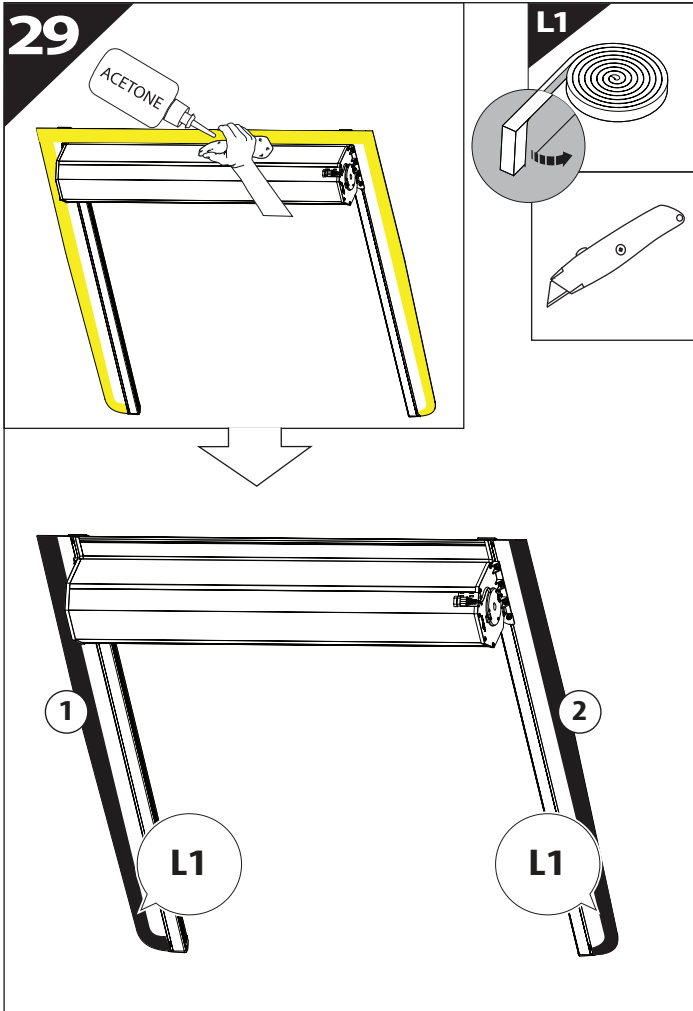

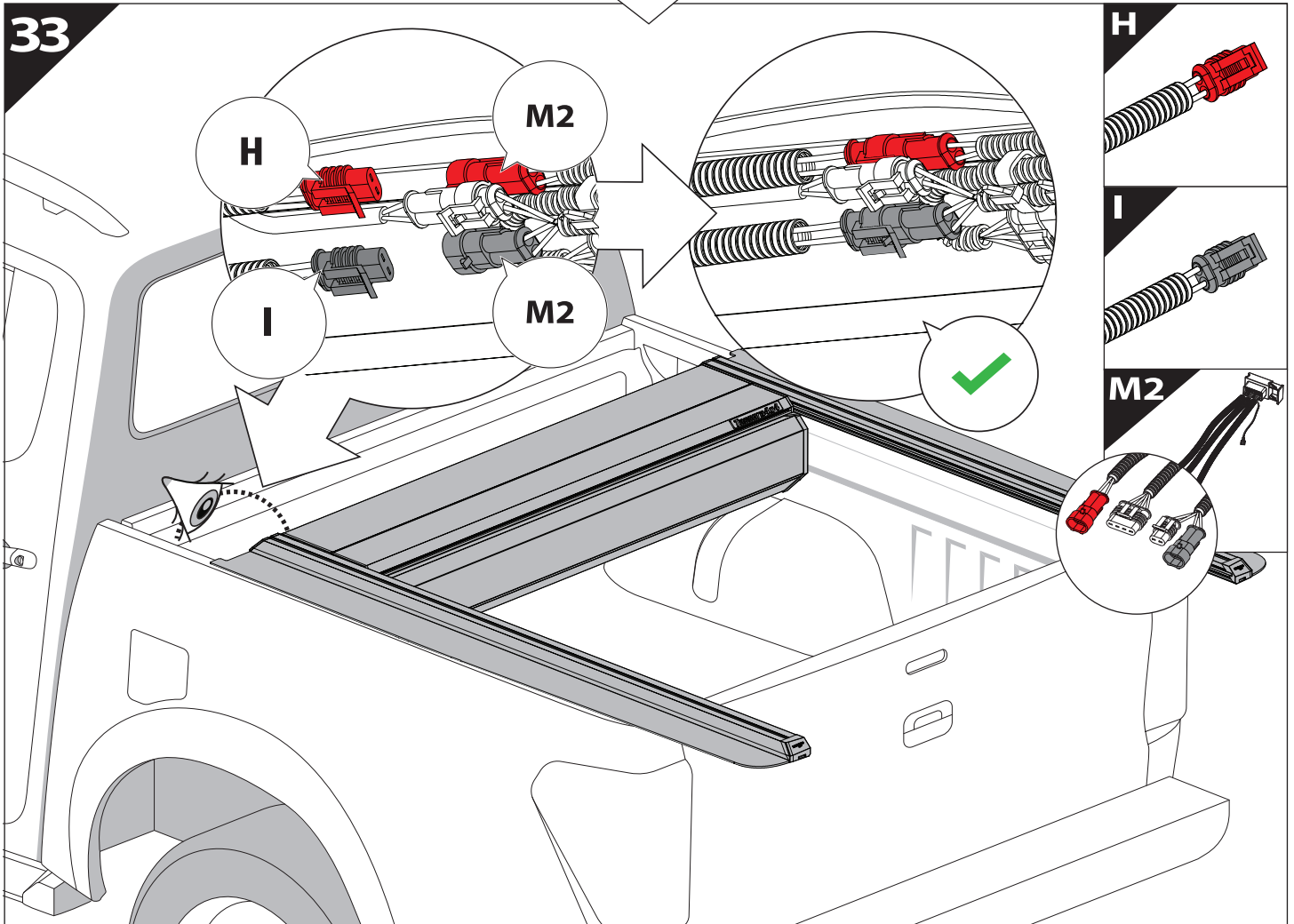
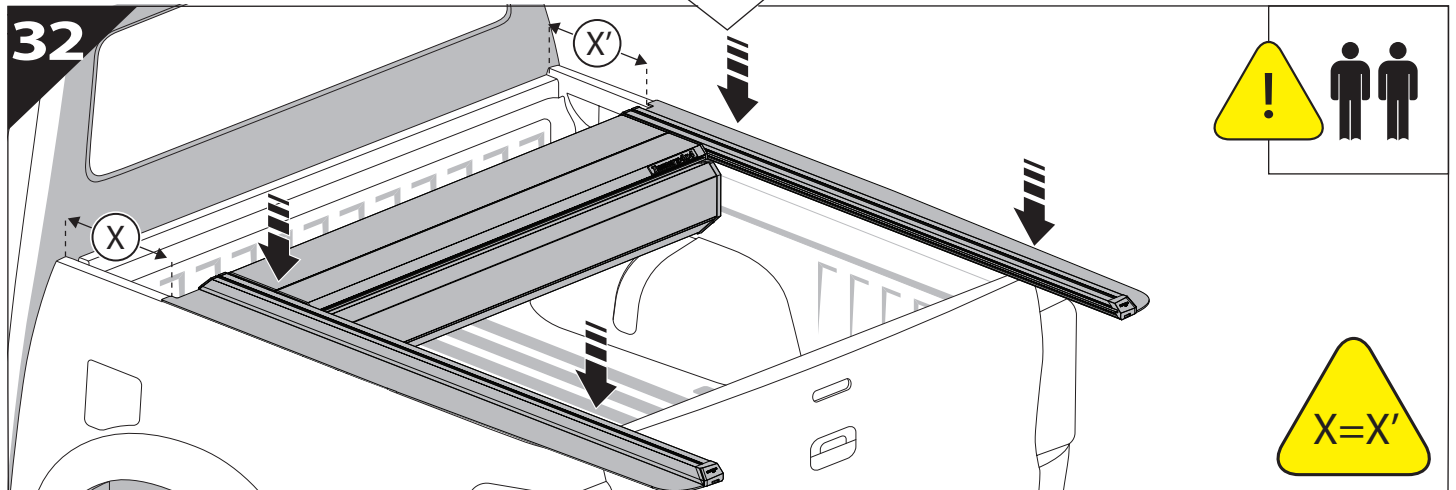
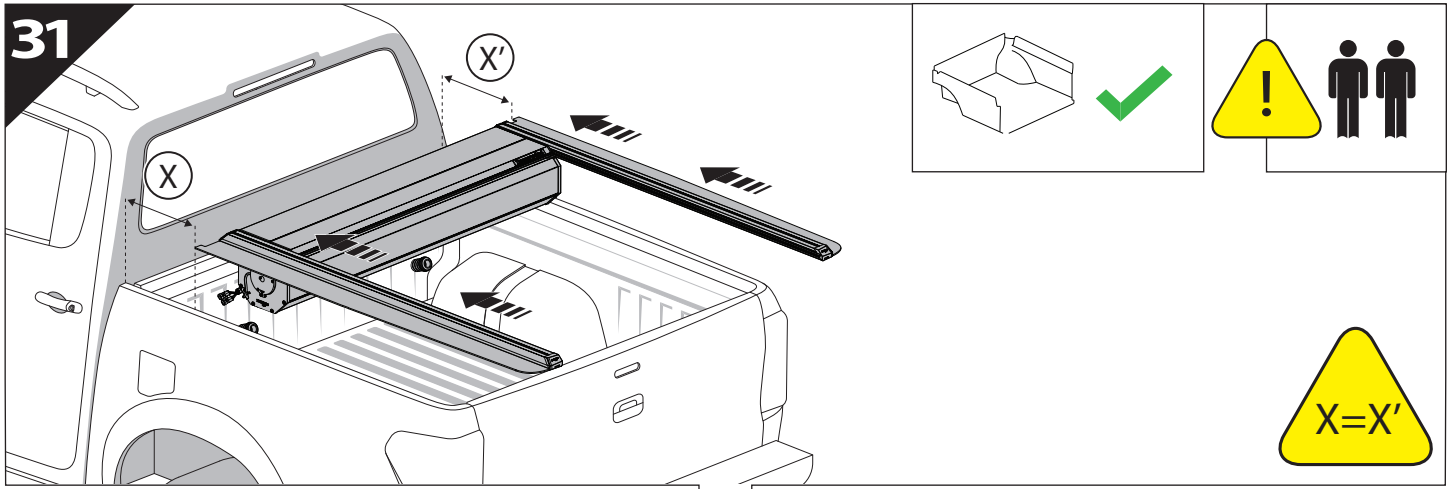

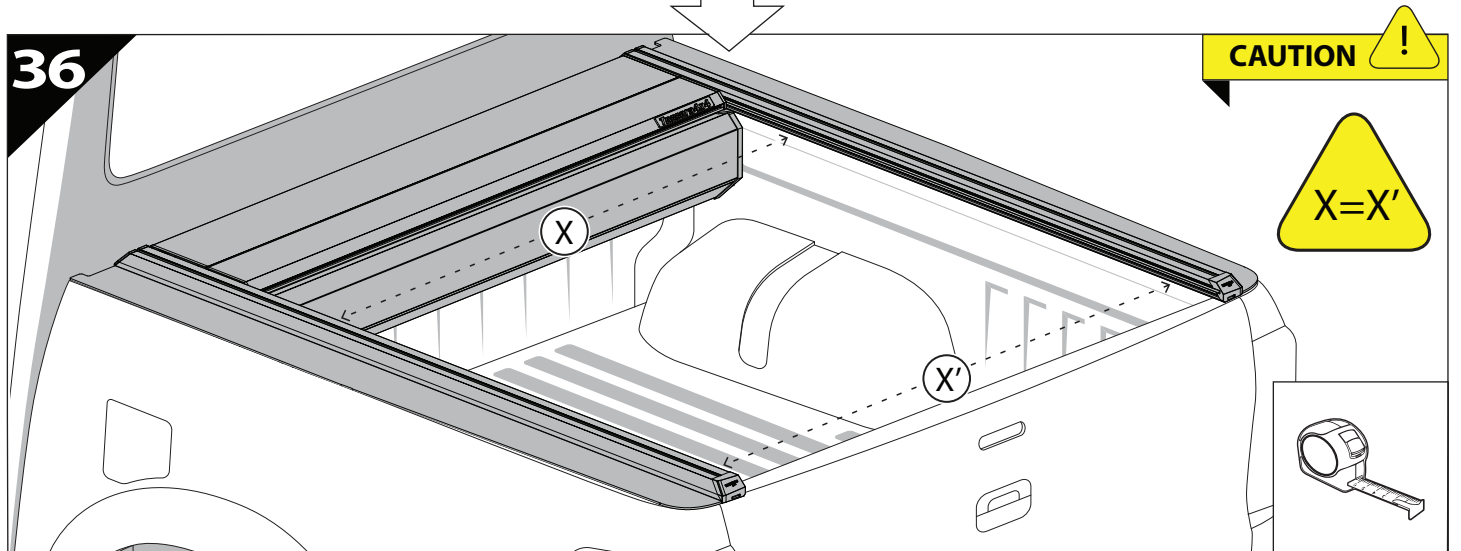
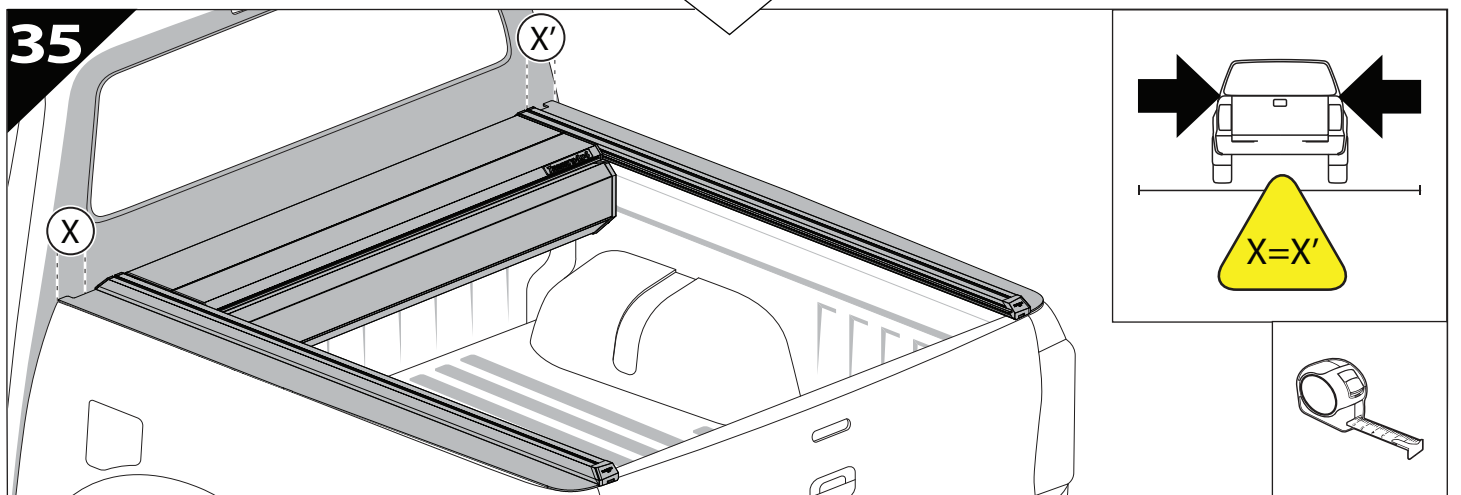
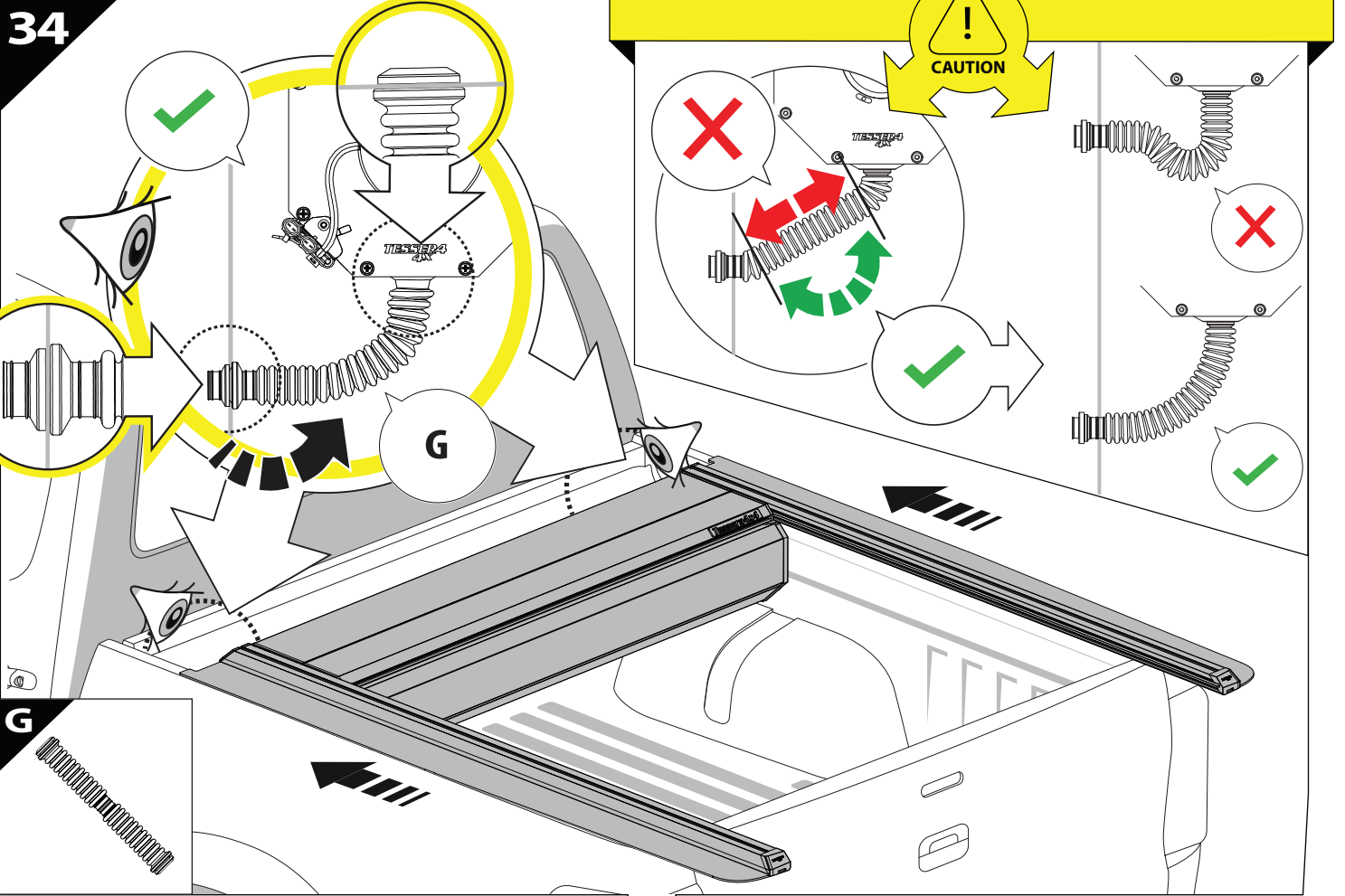

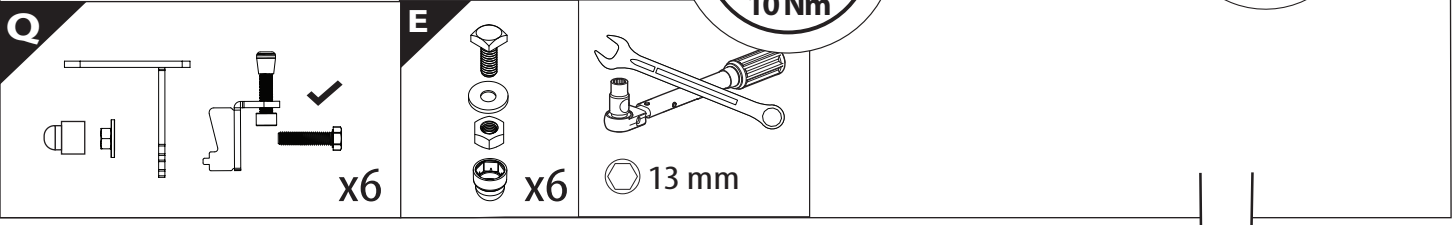
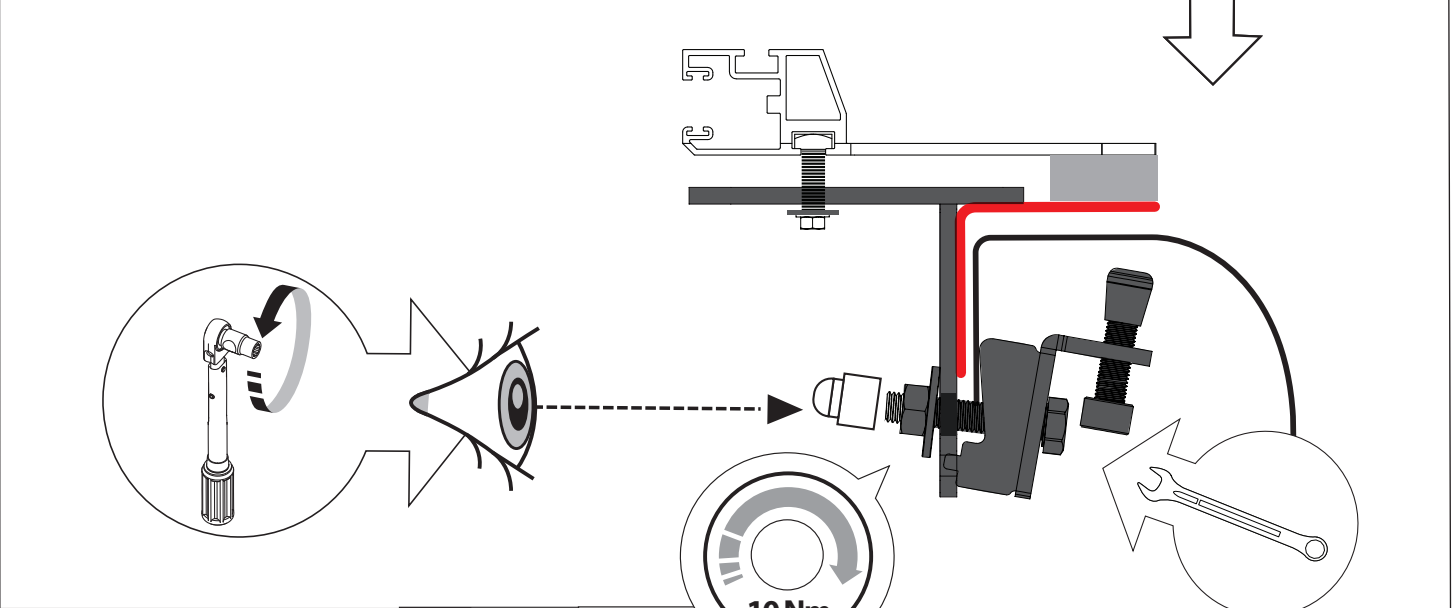
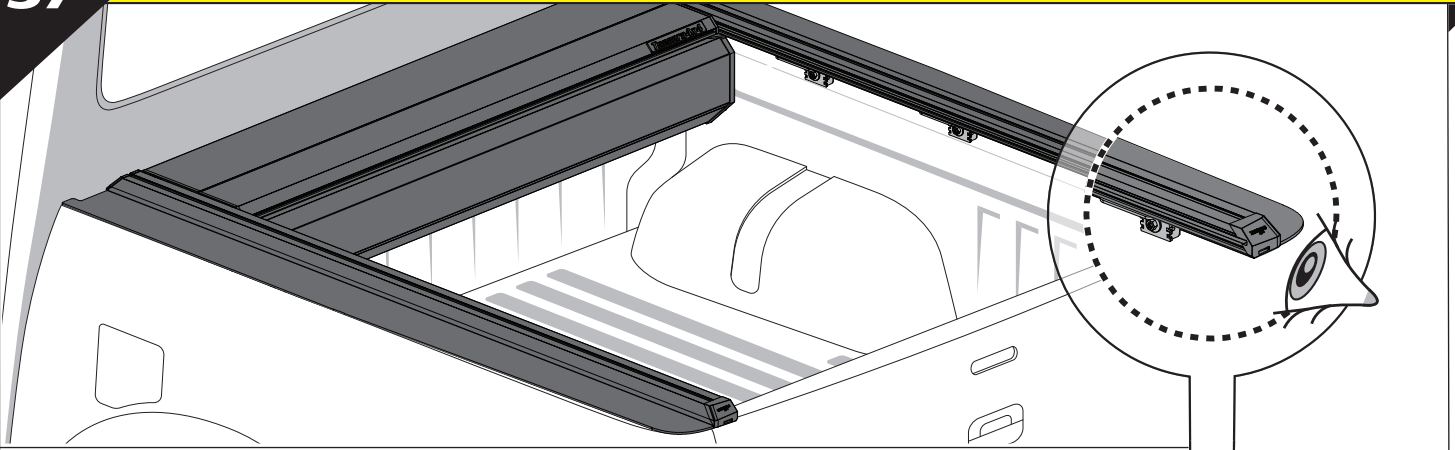

37.1

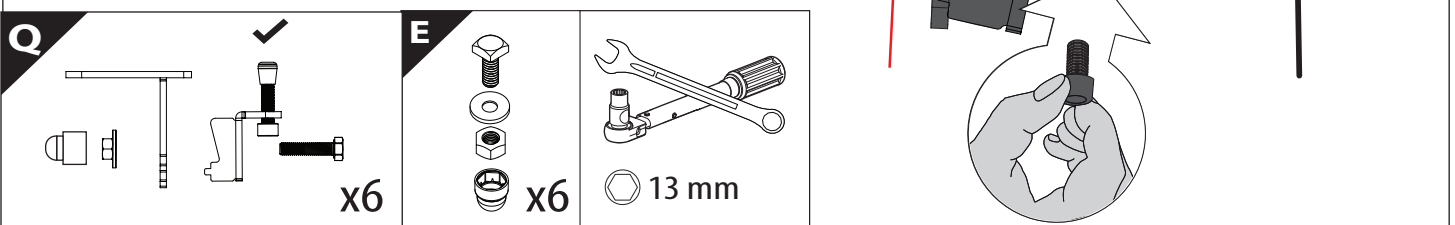
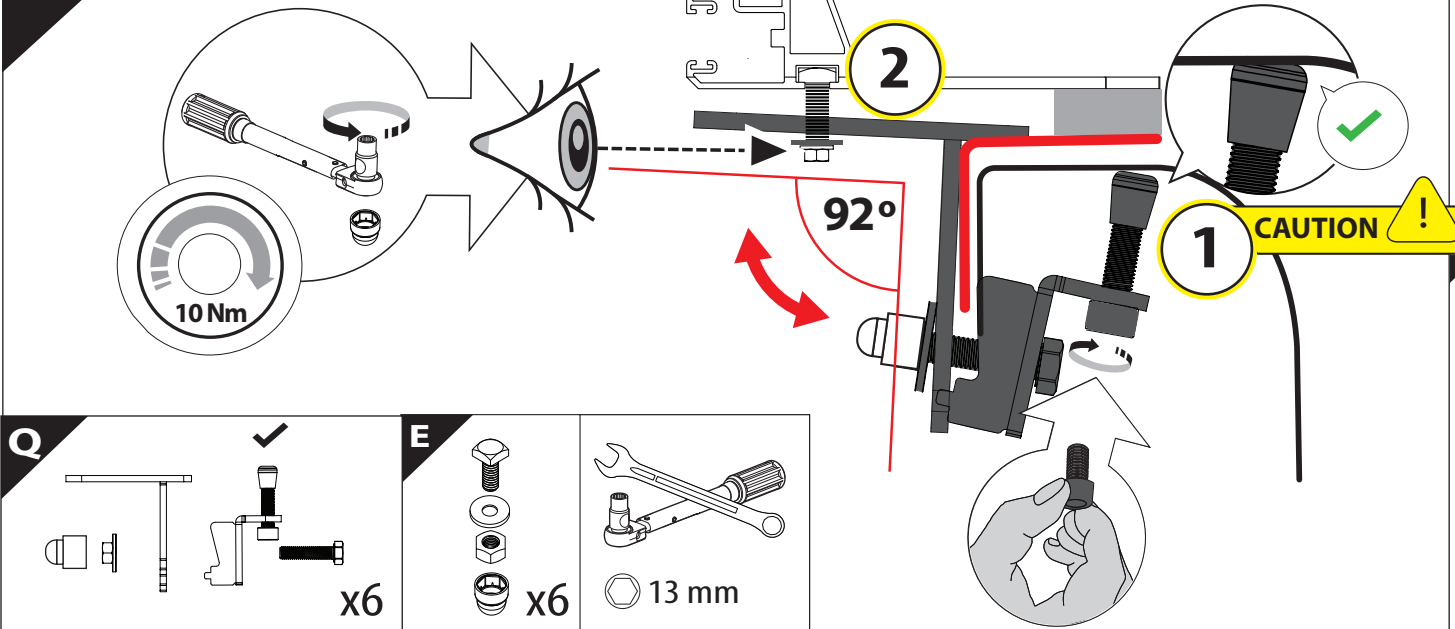

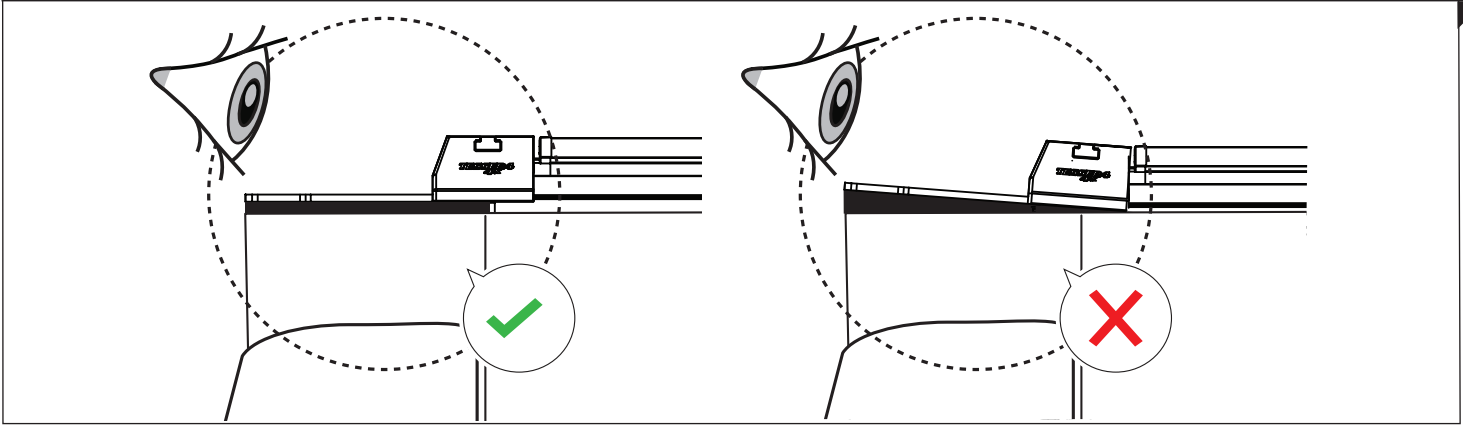
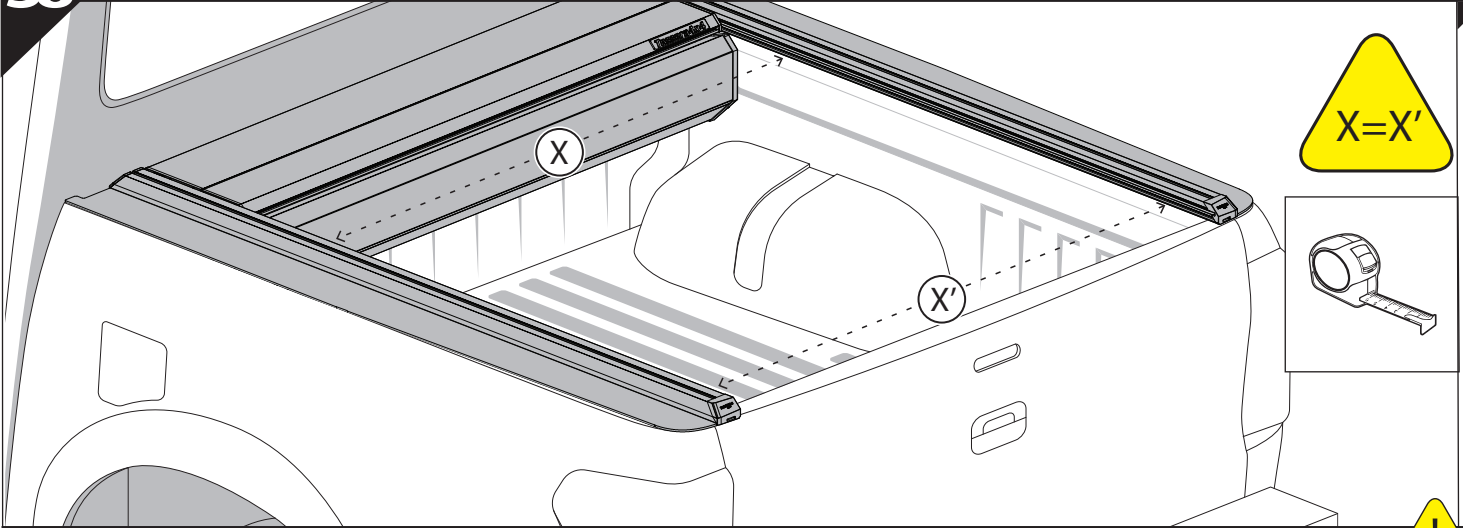

39

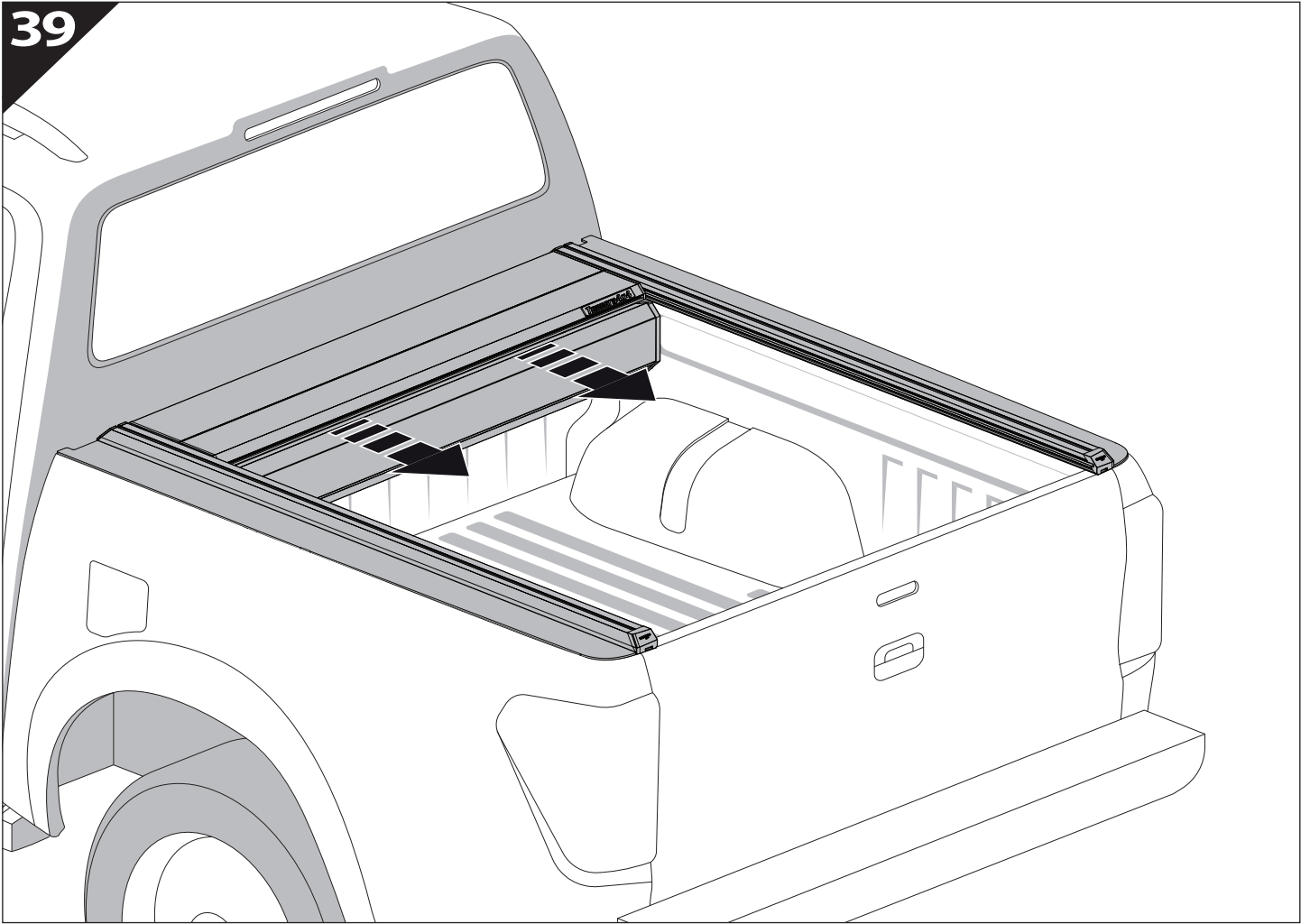

40

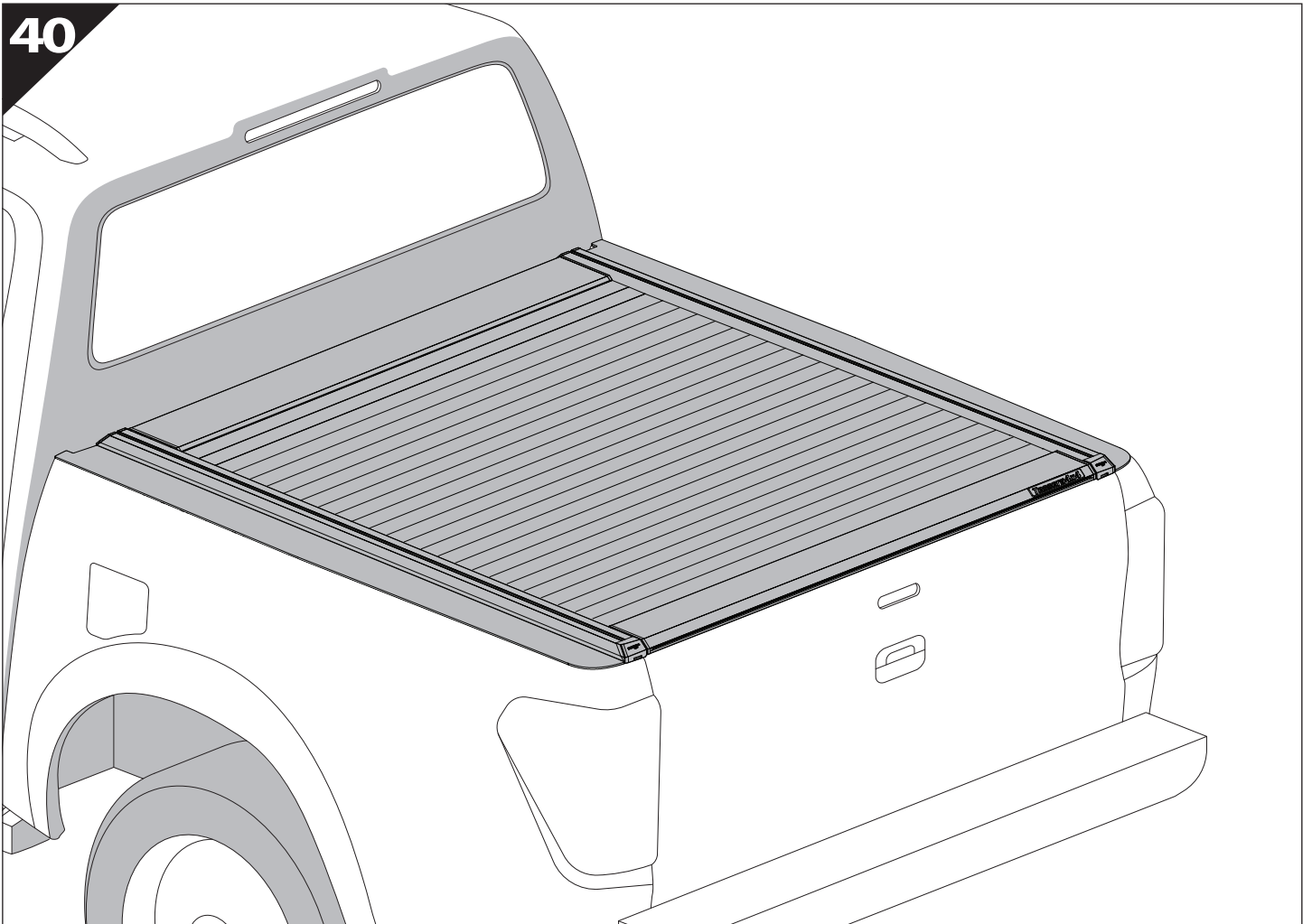







**GR:** Οδηγίες Εγκατάστασης  
**GB:** Installation manual  
**SF:** Asennusohje  
**F:** Notice de montage  
**PL:** Instrukcja montażu  
**NL:** Installatie-instructies  
**TR:** Montaj Talimatı  
**S:** Monteringsanvisning  
**E:** Instrucciones de montaje

**H:** Szerelési utasítás  
**P:** Instruções de instalação  
**RUS:** Инструкция по установке  
**N:** Monteringsveiledning  
**D:** Einbauanleitung  
**CZ:** Návod k instalaci  
**I:** Istruzioni de montaggio  
**DK:** Monteringsvejledning  
**RO:** Instructiuni de instalare

Customer Service:

+30 (210) 5541161, +30 (210) 5541154 (08:00 - 16:00 EET)

Support department:

[info@gianso.gr](mailto:info@gianso.gr)

Website:

[www.tessera4x4.com](http://www.tessera4x4.com)

Address:

19.5 km of National road Athens-Korinthos (Elefsina) Greece, P.C: 19200